

7800 Series Burner Control

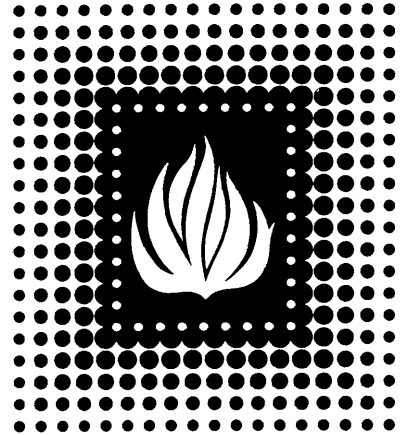

TOTAL BURNER CONTROL 7800 SERIES

7800 SERIES

The latest in Flame Safeguard state-of-the-art technology is the 7800 SERIES Burner Control. The Honeywell 7800 SERIES combines safety, comprehensive diagnostics, communication and networking capabilities into one compact and affordable microcomputer burner control. It can do just about anything and everything you would like it to do.

The 7800 SERIES works on a wide range of industrial applications: burners, boilers, furnaces, ovens, kilns, process heaters and more. The 7800 SERIES replaces more than 400 Honeywell and competitive control types. It offers you intelligent control anyway you want it: with or without communications, with or without an expanded annunciator, with or without a keyboard display module. Whatever features you want from a burner control, just ask. With the 7800 SERIES, the answer is...yes, it can.

COMMUNICATIONS INTERFACE

The 7800 SERIES can interface with compatible IBM® equivalent personal computers at an onsite or remote location through a communications interface.

Primary Relay Modules—Automatic

NOTE: CONTROLS FOR USE IN 7800 SERIES BURNER CONTROL SYSTEMS ARE AVAILABLE ONLY THROUGH AUTHORIZED HONEYWELL 7800 SERIES DISTRIBUTORS.

For the name of your nearest authorized Honeywell 7800 SERIES Distributor, please call 1-800-345-6770, ext. 2040.

RM7890A,B,C,D/EC7890A,B Primary Controls

Microprocessor-based integrated primary burner control for automatically fired gas, oil, coal or combination fuel single burner applications.

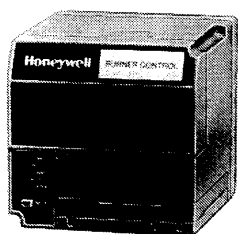

- Dependable, long-term operation provided by microcomputer technology.
- Five LEDs for sequence information.
- Nonvolatile memory retains history files and sequence status after loss of power.
- Optional remote reset.
- Provides application flexibility and optional communication interface capability.
- Safety features include closed loop logic test, expanded safe-start check, internal hardware status monitoring and tamper-resistant timing and logic. Dynamic Self-Check and Dynamic AMPLI-CHECK™ safety features available.
- Selectable recycle or lockout on loss of flame.
- Shutter drive output (RM7890B) for use with Dynamic Self-Check flame detectors.
- Works with existing flame detectors.

APPROVAL BODIES: RM7890

Underwriters Laboratories Inc. listed, File No. MP268, Guide No. MCCZ.

Canadian Standards Association certified, LR9S329-3. Factory Mutual approved.

IRI acceptable.

Federal Communications Commission: Part 15, Class B-Emissions.

DIMENSIONS: 5 in. [127 mm] wide, 5 in. [127 mm] high, 3-1/32 in. [77 mm] deep.

WEIGHT: 1 lb., 13 oz.

OPERATING AMBIENT TEMPERATURE RANGE: – 40 F to +140 F [–40 C to +60 C].

ELECTRICAL RATINGS:

Voltage and Frequency: 120 Vac (+10/ -15%), 50/60 Hz (±10%) RM7890A,B,C,D.

220-240 Vac (+10/ -15%), 50/60 Hz (±10%)

EC7890A,B.

REQUIRED COMPONENTS:

R7847, R7848, R7849, R7886A Flame Signal Amplifiers. Q7800 Universal Wiring Subbase.

OPTIONAL COMPONENTS:

Communications (see Communications Section).

S7800A Keyboard Display Module.

S7810A DATA CONTROLBUS MODULE™.

S7820A Remote Reset Module.

S7830A First-out Expanded Annunciator Module.

REPLACEMENT PART 221729 Dust Cover.

SEQUENCE TIMING FOR NORMAL OPERATION:

Model Number	Initiate	Standby	Pilot Flame Establishing Period (PFEP)	Run
RM7890A/ EC7890A	10 sec.	a	4 or 10sec. ^b	a
RM7890B/ EC7890B	10 sec.	a	4 or 10 sec.	a
RM7890C	10 sec.	a	Not Applic.	a
RM7890D	10 sec.	a	15/30 sec.	a

^aSTANDBY & RUN can be an infinite time period. ^bRM7890A1031—30 PFEP

Order Number	Description	Replaces ^a
RM7890A1015/ EC7890A1011	Automation primary relay module, 50/60 Hz	RA890F, G, H
RM7890A1031/	Automatic primary relay module, 30 sec. PFEP	RA890F, G, H
RM7890B1014/ EC7890B1010	Automatic primary relay module, shutter drive, 50/60 Hz	RA890F, G, H
RM7890C1005	Automatic primary relay module, 60 Hz, standing pilot	
RM7890D1004	Automatic primary relay module, 60 Hz for direct spark infrared heater application, Flame rods only	

^aTo replace RA890F, select R7847A Flame Signal Amplifier. To replace RA890G, select R7849A Flame Signal Amplifier. To replace RA890H, select R7847B Flame Signal Amplifier. Check timings for application requirements.

Primary Relay Modules-Automatic

RM7895A,B,C,D,E, F/EC7895A,C Primary Controls

Microprocessor-based integrated primary burner control for automatically fired gas, oil, coal or combination fuel single burner applications.

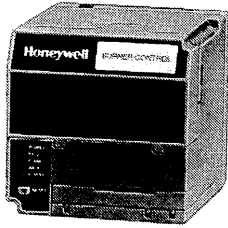

- Dependable, long-term operation provided by microcomputer technology.
- Five LEDs for sequence information.
- Nonvolatile memory retains history files and sequence status after loss of power.
- Optional remote reset.
- Provide application flexibility and optional communication interface capability.
- RM7895C,D;EC7895C have delayed main valve.
- Safety features include airflow switch check, closed loop logic test, expanded safe-start check, internal hardware status monitoring and tamper-resistant timing and logic. Dynamic Self-Check and Dynamic AMPLI-CHECK™ safety feature available.
- Selectable lockout or recycle on flame failure.
- Selectable lockout or recycle on loss of airflow.
- Works with existing flame detectors.

APPROVAL BODIES: RM7895

Underwriters Laboratories Inc. listed, File No. MP268, Guide No. MCCZ.

Canadian Standards Association certified, LR9S329-3.

Factory Mutual approved.

IRI acceptable.

Federal Communications Commission: Part 15, Class B-Emissions.

DIMENSIONS: 5 in. [127 mm] wide, 5 in. [127 mm] high, 3-1/32 in. [77 mm] deep.

WEIGHT: 1lb., 13 oz.

OPERATING AMBIENT TEMPERATURE RANGE: - 40 F to +140 F [-40 C to +60 C].

ELECTRICAL RATINGS:

Voltage and Frequency: 120 Vac (+10/ - 15%), 50/60 Hz

(±10%) RM7895A,B,C,D,E,F.

220-240 Vac (+10/ -1 5%), 50/60 Hz (±10%)

EC7895A,C.

REQUIRED COMPONENTS:

Q7800 Universal Wiring Subbase.

R7847, R7848, R7849, R7886 Flame Signal Amplifiers.

ST7800 Plug-in Purge Timers.

OPTIONAL EQUIPMENT

Communications (see Communications Section).

S7800 Keyboard Display Module.

S7810 DATA CONTROLBUS MODULE™.

S7820 Remote Reset Module.

S7830 First-out Expanded Annunciator.

SEQUENCE TIMING FOR NORMAL OPERATION:

REPLACEMENT PART 221729 Dust Cover.

Model Number	Initiate	Standby	Purge	Flame Establishing Period		Airflow Switch Check (AFSC)	Delay Main Valve
				Pilot	Main		
RM7895A/EC7895A	10 sec.	a	b	4 or 10 sec.	No	No	No
RM7895B/EC7895B	10 sec.	a	b	4 or 10 sec.	No	Yes	No
RM7895C	10 sec.	a	b	4 or 10 sec.	10 sec.	No	Yes
RM7895D	10 sec.	a	b	4 or 10 sec.	10 sec.	Yes	Yes
RM7895E	10 sec.	a	b	15 or 30 sec.	No	No	No
RM7895F	10 sec.	a	b	15 or 30 sec.	No	Yes	No

Order Number	Description	Replaces ^c
RM7895A1014	Intermittent primary relay module without AFSC, 50/60 Hz	R7795A, B
EC7895A1010	Intermittent primary relay module without AFSC, 50/60 Hz	
RM7895A1048	Intermittent primary relay module without AFSC, 50/60 Hz Termination of spark upon detection of flame	R7795A, B
RM7895B1013	Intermittent primary relay module with AFSC, 50/60 Hz	R7795E,F
EC7895C1000	Intermittent primary relay module with AFSC, 50/60 Hz	
RM7895C1012	Interrupted primary relay module without AFSC, 50/60 Hz	R7795C,D
RM7895C1020	Interrupted primary relay module without AFSC, fixed 10 sec. PFEP, termination of spark upon detection of flame, 50/60 Hz	R7795C,D
RM7895D1011	Interrupted primary relay module with AFSC, 50/60 Hz	
RM7895E1002	Intermittent primary relay module with AFSC, 50/60 Hz for direct spark infrared heater, flame rods only	
RM7895F1001	Interm, tent primary module with AFSC, 50/60 Hz for direct spark infrared heater, flame rods only	

^aSTABNDBY an RUN can be an infinite time period. ^bPURGE will be determined by which ST7800 Purge card is selected.

^cTo replace R7795A, C, E, F, select R7849A Flame Signal Amplifier. To replace R7795B, D, F, H, select R7847A Flame Signal Amplifier.

Primary Relay Modules—Automatic

RM7824A Primary Control

Microprocessor-based integrated primary burner control for automatically fired gas, oil, coal or combination fuel single burner applications.

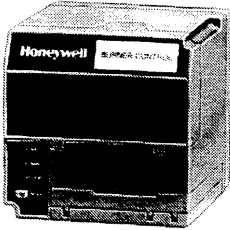

- Dependable, long-term operation provided by microcomputer technology.
- Five LEDs for sequence information.
- Nonvolatile memory retains history files and sequence status after loss of power.
- Optional remote reset.
- Provide application flexibility and optional communication interface capability.
- Safety features include closed loop logic test, expanded safe-start check, internal hardware status monitoring and tamper-resistant timing and logic. Dynamic Self-Check available.
- Selectable 10 or 4 second Pilot Flame Establishing Period.
- Works with C7024E, F Ultraviolet Dynamic Self-Check Flame Detector/R7824C Amplifier or C7015 Infrared Flame Detector and R7848A,B Amplifier.

APPROVAL BODIES:

Underwriters Laboratories Inc. listed, File No. MP268, Guide No. MCCZ.
 Canadian Standards Association certified, LR9S329-3.
 Federal Communications Commission: Part 15, Class B—Emissions.

DIMENSIONS: 5 in. (127 mm) wide, 5 in (127 mm) high, 3-1/32 in (77 mm) deep.

WEIGHT 1 lb., 13 oz.

OPERATING AMBIENT TEMPERATURE RANGE: -40°F to +140°F (-40°C to +60°C).

ELECTRICAL RATINGS:

Voltage: 24 Vdc, +7%, -85
 Power Dissipation: 10W maximum

REQUIRED COMPONENTS:

Q7800A,B Universal Wiring Subbase.
 R7824C1002 Dynamic Self-Check Amplifier 3.0 sec FFRT used with C7024E, F.
 R7848A1008 Infrared or C7015A Infrared Flame Detector 3.0 sec. FFRT, used with C7015A.
 R7848B1006 Dynamic Ampli-Check® 3.0 sec. FFRT used with C7015A.

REPLACEMENT PART 221729 Dust Cover.

SEQUENCE TIMING FOR NORMAL OPERATION OF THE PRIMARY RELAY:

Device	Initiate	Standby	Pilot Flame Establishing Period	Run
RM7824A1006	10 sec.	*	4 or 10 sec.	*

* STANDBY and RUN can be infinite time period.

AMPLIFIER:

Order Number	Description
R7824C1002	Amplifier for Primary Relay Module -24 Vdc Input - used with C7024E, F
R7848A1008	Amplifier for Primary Relay Module -3.0 FFRT- used with C7015A
R7848B1006	Amplifier for Primary Relay Module -3.0 FFRT - Ampli-Check®

Primary Relay Modules—Semi-Automatic

RM7823A/EC7823A Primary Flame Switch

Microprocessor-based integrated flame switch for detecting a flame using rectification, ultraviolet (UV) or infrared (IR) source.

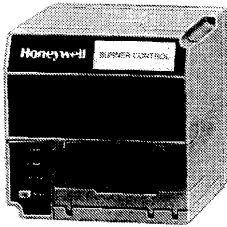

- Dependable, long-term operation provided by microcomputer technology.
- Provides two spdt switching outputs.
- Three LEDs for power, flame and alarm.
- Used with rectification, ultraviolet or infrared flame detectors.
- Works with existing flame detectors.

APPROVAL BODIES: RM7823A

Underwriters Laboratories Inc. listed, File No. MP268, Guide No. MCCZ.
Canadian Standards Association certified, LR9S329-3.
Factory Mutual approved.
IRI acceptable.
Federal Communications Commission: Part 15, Class B-Emissions.

DIMENSIONS: 5 in. [127 mm] high, 5 in. [127 mm] wide, 3-1/2 in. [77 mm] deep.

WEIGHT 1 lb., 13 oz.

AMBIENT TEMPERATURE RANGE: -40 F to +140 F
[-40 C to +60 C].

ELECTRICAL RATING:

Voltage and Frequency: 120 Vac (+10/-15%), 50/60 Hz (±10%)
RM7823A.

220-240 Vac (+10/-15%), 50/60 Hz (±10%) EC7823A.

CONTACT RATING; (Pilot Duty): 10A -1 VA.

REQUIRED COMPONENTS:

Q7800 Universal Wiring Subbase.

R7847, R7848, R7849, R7886 Flame Signal Amplifiers.

OPTIONAL COMPONENTS:

Communications (see Communications Section).

S7800 Keyboard Display Module.

S7810 DATA CONTROLBUS MODULE™.

S7820 Remote Reset Module.

REPLACEMENT PART: 221729 Dust Cover.

Order Number	Voltage	Switching	Replaces*
RM7823A1016	120 Vac, 50/60 Hz	Two spdt	R7023B,C
EC7823A1004	220-240 Vac, 50/60 Hz	Two spdt	—

*To replace R7023B, select R7847 Flame Signal Amplifier. To replace 7023C, select R7849 Flame Signal Amplifier.

Primary Relay Modules—Semi-Automatic

RM7885A/EC7885A Semi-Automatic Primary Control

Microprocessor-based integrated burner control for industrial semi-automatically fired, gas, oil, coal, or combination fuel single burner applications.

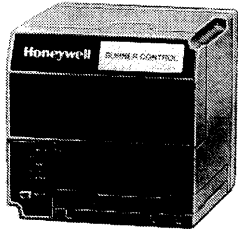

DIMENSIONS: 5 in. [127 mm] high, 5 in. [127 mm] wide, 3-1/2 in. [77 mm] wide.

WEIGHT 1 lb., 13 oz.

AMBIENT TEMPERATURE RANGE: -40 F to +140 F [-40 C to +60 C].

ELECTRICAL RATINGS:

Voltage and Frequency 120 Vac (+10/-15%), 50/60 Hz (±10%) RM7885A.

220-240 Vac (+10/ -15%), 50/60 Hz (±10%) EC7885A.

- Delays admission of fuel to combustion chamber until pilot flame has been proven.
- Dependable, long-term operation provided by microcomputer technology.
- Five LEDs for sequence information.
- Has nonvolatile memory; retains history files and sequencing status after loss of power.
- Optional remote reset.
- Provides application flexibility and optimal communications interface capability.
- Provides flame signal check during standby.
- Safety features include closed loop logic test, expanded safe-start check, internal hardware status monitoring and tamper-resistant timing and logic. Dynamic Self-Check and Dynamic AMPLI-CHECK™ safety features available.

REQUIRED COMPONENTS:

Q7800 Universal Wiring Subbase.

R7847, R7848, R7849, R7886 Flame Signal Amplifiers.

OPTIONAL COMPONENTS:

Communications (see Communications Section).

S7800 Keyboard Display Module.

S7810 DATA CONTROLBUS MODULE™.

S7820 Remote Reset Module.

S7830 First-out Expanded Annunciator.

REPLACEMENT PART: 221729 Dust Cover.

SEQUENCE TIMING FOR NORMAL OPERATION:

Model Number	Initiate	Standby	Run
RM7885A	10 sec.	a	a

*STANDBY and RUN can be indefinite.

APPROVAL BODIES: RM7885A

Underwriters Laboratories Inc. listed, File No. MP268, Guide No. MCCZ.

Canadian Standards Association certified, LR9S329-3. Factory Mutual approved.

IRI acceptable.

Federal Communications Commission: Part 15, Class B-Emissions.

Order Number	Voltage	Alarm	Replaces*
RM7885A1015	120 Vac, 50/60 Hz	Terminal provided for external alarm to sound on flame failure.	R485
EC7885A1011	220-240 Vac, 50/60 Hz	Terminal provided for external alarm to sound on flame failure.	R485

*To replace R485, select R7847 Flame Signal Amplifier.

Primary Relay Modules—Semi-Automatic

RM7838A Semi-Automatic Programmer

Microprocessor-based integrated burner control for industrial semi-automatically fired gas, oil, coal or combination fuel single burner applications.

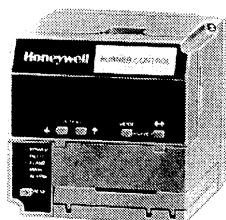

- Delays admission of fuel to combustion chamber until pilot flame has been proven and then to monitor the flame through the run period while providing system status indication.
- Dependable, long-term operation provided by microcomputer technology.
- Programmed to provide level of safety, functional capability and features beyond the capacity of conventional controls.
- Functions include purge, burner pilot startup, flame supervision, system status indication, system or self diagnosis and troubleshooting.
- Intermittent pilot valve.
- Safety features include closed loop logic test, expanded safe-start check, internal hardware status monitoring, and tamper resistant timing and logic. Dynamic Self-Check and Dynamic AMPLI-CHECK™ safety features available.
- Provides application flexibility and optional communication interface capability.
- Selectable pilot flame establishing period.

APPROVAL BODIES:

Underwriters Laboratories Inc. listed, File No. MP268, Guide No. MCCZ.
 Canadian Standards Association certified, LR9S329-3.
 Factory Mutual approved, Report No. JI1V9A0.AF.
 IRI acceptable.
 Federal Communications Commission: Part 15, Class B-Emissions.

DIMENSIONS: 5 in. [127 mm] wide, 5 in. [127 mm] high, 3-1/32 in. [77 mm] deep.

WEIGHT: 1 lb., 10 oz.

OPERATING AMBIENT TEMPERATURE RANGE: -40 F to +140 F [-40 C to +60 C].

ELECTRICAL RATINGS:

Voltage and Frequency 120 Vac (+10/-15%), 50/60 Hz (±10%)

REQUIRED COMPONENTS:

Q7800 Universal Wiring Subbase.
 R7847, R7848, R7849, R7886 Flame Signal Amplifiers.
 ST7800 Plug-in Purge Timer Card.

OPTIONAL COMPONENTS:

Communications (see Communications section).
 S7800 Keyboard Display Module.
 S7810 DATA CONTROLBUS MODULE.™
 S7820 Remote Reset Module.
 S7830 First-out Expanded Annunciator.

SEQUENCE TIMING FOR NORMAL OPERATION:

Model Number	Initiate	Standby	Purge	Pilot Flame Establishing Period (PFEP)	Run
RM7838A	10 sec.	a	b	4 or 10 sec.	a

^aSTANDBY and RUN can be an indefinite time period.

^bPURGE will be determined by ST7800A Plug-in Purge Timer Card.

Order Number	Description	Replaces
RM7838A1014	Semi-automatic industrial primary relay module with display; 50/60 Hz.	R4138A,C

Primary Relay Modules—Semi-Automatic

RM7838B Semi-Automatic Programmer

Microprocessor-based integrated burner control for industrial semi-automatically fired gas, oil, coal or combination fuel single burner applications.

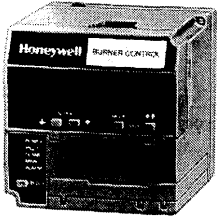

- Functions include automatic modulated purge, a special Pilot Valve Hold,* manual open valve input, flame supervision, system status indication, system or self-diagnosis and troubleshooting.
- Programmed to provide level of safety, functional capability and features beyond the capacity of conventional controls.
- Provide application flexibility and optional communication interface capability.
- Safety features include closed loop logic test, expanded safe-start check, internal hardware status monitoring, high fire and low fire start switch test and tamper resistant timing and logic. Dynamic Self-Check and Dynamic AMPLI-CHECK™ safety features available.
- Selectable Pilot Flame Establishing Period (PFEP).
- Selectable Intermittent or Interrupted Pilot Valve.
- Selectable purge timing.
- Selectable Main Flame Establishing Period (MFEP) (deferred or immediate).

* US patent issued

- Use with R7847C or R7886A, D Plug-in Flame Signal Amplifiers for Pilot Valve Hold.

APPROVAL BODIES:

Underwriters Laboratories Inc. listed, File No. MP268, Guide No. MCCZ.
 Canadian Standards Association certified, LR9S329-3.
 Factory Mutual approved, Report No. JI1V9A0.AF.
 IRI acceptable.
 Federal Communications Commission: Part 15, Class B-Emissions.

DIMENSIONS: 5 in. [127 mm] wide, 5 in. [127 mm] high, 3-1/32 in. [77 mm] deep.

WEIGHT 1 lb., 10 oz.

OPERATING AMBIENT TEMPERATURE RANGE: -40 F to +140 F [-40 C to +60 C].

ELECTRICAL RATINGS:

Voltage and Frequency: 120 Vac (+10/-15%), 50/60 Hz (±10%)

REQUIRED COMPONENTS:

Q7800 Universal Wiring Subbase.
 R7847C, R7861Ag, or R7886A Flame Amplifiers for Pilot Valve Hold, or R7847A,B, R7848A,B, R7849A,B for standard combustion applications.
 ST7800 Plug-in Purge Timer Card.
 S7800 Keyboard Display Module.

OPTIONAL COMPONENTS:

Communications (see Communications section).
 S7810 DATA CONTROLBUS MODULE™.
 S7820 Remote Reset Module.
 S7830 First-out Expanded Annunciator.

SEQUENCE TIMING FOR NORMAL OPERATION:

Device	Initiate	Standby	Purge	Pilot Flame Establishing Period (PFEP)	Main Flame Establishing Period (MFEP)	Run
RM7838B	10 sec.	a	b	4 sec or 10 sec.	10 sec. ^c	a

^aSTANDBY and RUN can be an indefinite time period.

^bPURGE will be determined by which ST7800A plug-in Purge Timer Card is selected.

^cImmediate or deferred main flame.

Order Number	Description
RM7838B1013	Enhanced semi-automatic industrial primary relay module with display: 50/60 Hz.

RM7840E,G,L,M Programmer

Microprocessor-based integrated burner control for automatically fired gas, oil, coal or combination fuel single burner applications.

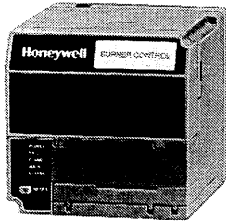

- Dependable, long-term operation provided by microcomputer technology.
- Nonvolatile memory retains history files and sequence status after loss of power.
- Options include Keyboard Display Module, Personal Computer Interface, DATA CONTROLBUS MODULE™, Remote Display Mounting and First Out Expanded Annunciator.
- Programmed to provide level of safety, functional capability and features beyond capacity of conventional controls.
- Provides automatic burner sequencing, flame supervision, system status indication, system and self-diagnostics and troubleshooting.
- Works with existing flame detectors.
- Safety features include closed loop logic test, expanded safe-start check, internal hardware™ status monitoring, and tamper-resistant timing and logic. Dynamic Self-Check and Dynamic AMPLI-CHECK™ safety features available.

APPROVAL BODIES:

Underwriters Laboratories Inc. listed, File No. MP268, Guide No. MCCZ.
 Canadian Standards Association certified, LR9S329-3.
 Factory Mutual approved, Report No. JI1 V9A0.AF.
 IRI acceptable.
 Federal Communications Commission: Part 15, Class B-Emissions.

DIMENSIONS: 5 in. [127 mm] wide, 5 in. [127 mm] high, 3-27/32 in. [98 mm] deep.

WEIGHT: 1 lb., 13 oz.

OPERATING AMBIENT TEMPERATURE RANGE: – 40 F to +140 F [–40 C to +60 C].

ELECTRICAL RATINGS:

Voltage and Frequency: 120 Vac (+10/-15%), 60 Hz (±10%)
 RM7840G, M
 120 Vac (+10/-15%), 50/60 Hz (±10%) RM7840E, L

REQUIRED COMPONENTS:

Q7800 Universal Wiring Subbase.
 R7847, R7848, R7849, R7886 Flame Signal Amplifiers.
 ST7800 Plug-in Purge Timer Cards.

OPTIONAL COMPONENTS:

Communications (see Communications Section).
 S7800 Keyboard Display Module.
 S7810 DATA CONTROLBUS MODULE™.
 S7820 Remote Reset Module.
 S7830 First-out Expanded Annunciator.

SEQUENCE TIMING FOR NORMAL OPERATION:

Model Number	Initiate	Standby	Purge	Pilot Flame Establishing Period (PFEP)	Main Flame Establishing Period (MFEP) ^a	Run	Postpurge
RM7840E ^a	10 sec.	b	c	4 or 10 sec.	10 or 15 sec.	b	15 sec.
RM7840G	10 sec.	b	c	4 or 10 sec.	10, 15, 30 or Intermittent	b	15 sec.
RM7840L	10 sec.	b	c	4 or 10 sec.	10 or 15 sec.	b	15 sec.
RM7840M	10 sec.	b	c	4 or 10 sec.	10 sec. or Intermittent	b	15 sec.

a Energy Saving Prepurge.

b STANDBY and RUN can be an indefinite time period.

c PURGE is determined by ST7800 Plug-in purge Timer Card selected.

d The MFEP will be determined by terminal used, configuration jumper or jumper wire addition. See instruction sheet.

REPLACEMENT PART 221729 Dust Cover.

Order Number	Description	Replaces
RM7840E1016	Relay module with ESP ^a , without display, 50/60 Hz.	—
RM7840G1014	Relay module without display, 60 Hz.	R4140G
RM7840L1018	Relay module without display, 50/60 Hz.	R4140L
RM7840M1017	Relay module without display, 60 Hz.	R4140M
RM7840L1026	Relay module without display, 50/60 Hz, Intermittent Pilot	R4140L

^aESP—Energy Saving Prepurge

Programmiers

RM7800E,G,L,M Programmiers

Microprocessor-based integrated burner control for automatically fired gas, oil, coal or combination fuel single burner applications.

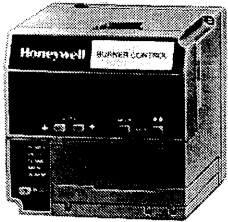

- Dependable, long-term operation provided by microcomputer technology.
- Nonvolatile memory retains history files and sequencing status after loss of power.
- Options include Personal Computer Interface, DATA CONTROLBUS MODULE™, Remote Display Mounting and First-out Expanded Annunciator.
- Programmed to provide level of safety, functional capability and features beyond the capacity of conventional controls.
- Provides application flexibility and communication interface capability.
- Provides automatic burner sequencing, flame supervision, system status indication, system and self-diagnostics and troubleshooting.
- Safety features include airflow switch check, closed loop logic test, dynamic input test, expanded safe start check, low fire start switch test, and tamper-resistant timing and logic. Dynamic Self-Check and Dynamic AMPLI-CHECK™ safety features available.

- Work with existing flame detectors.

APPROVAL BODIES:

Underwriters Laboratories Inc. listed, File No. MP268, Guide No. MCCZ.

Canadian Standards Association certified, LR9S329-3. Factory Mutual approved, Report No. JI1V9A0.AF.

IRI acceptable.

Federal Communications Commission: Part 15, Class B-Emissions.

DIMENSIONS: 5 in. [127 mm] wide, 5 in. [127 mm] high, 3-1/32 in. [77 mm] deep.

WEIGHT 1 lb., 13 oz.

OPERATING AMBIENT TEMPERATURE RANGE: - 40 F to +140F [-40 C to +60 C].

ELECTRICAL RATINGS:

Voltage and Frequency: 120 Vac (+10/-15%), 60 Hz (±10%)

RM7800E, G, M

120 Vac (+10/-15%), 50/60 Hz (±10%) RM7800L

REQUIRED COMPONENTS:

Q7800 Universal Wiring Subbase.

R7847, R7848, R7849, R7886 Flame Signal Amplifiers.

S7800 Keyboard Display Module.

ST7800 Plug-in Purge Timer Card.

OPTIONAL COMPONENTS:

Communications (see Communications section).

S7810 DATA CONTROLBUS MODULE.™

S7820 Remote Reset Module.

S7830 First-out Expanded Annunciator.

SEQUENCE TIMING FOR NORMAL OPERATION:

Model Number	Initiate	Standby	Purge	Pilot Flame Establishing Period (PFEP)	Main Flame Establishing Period (MFEP) ^d	Run	Postpurge
RM7800E ^a	10 sec.	b	c	4 or 10 sec.	10 or 15 sec.	b	15 sec.
RM7800G	10 sec.	b	c	4 or 10 sec.	10, 15, 30 or Intermittent	b	15 sec.
RM7800L	10 sec.	b	c	4 or 10 sec.	10 or 15 sec.	b	15 sec.
RM7800M	10 sec.	b	c	4 or 10 sec.	10 sec. or Intermittent	b	15 sec.

a Energy Saving Prepurge.

b STANDBY and RUN can be an infinite time period.

c PURGE will be determined by which ST7800A Purge Timer Card is selected.

d The MFEP will be determined by terminals used, configuration jumper or jumper wire addition. See instruction sheet.

Order Number	Description	Replaces
RM7800E1010	Automatic programming control with ESP ^a and display, 60 Hz.	BC7000L; PM720L
RM7800G1018	Automatic programming control with display, 60 Hz.	BC7000L; PM720G
RM7800L1012	Automatic programming control with display, 50/60 Hz.	BC7000L; PM720L
RM7800M1011	Automatic programming control with display, 60 Hz.	BC7000L; PM720M
RM7800L1053	Automatic programming control with display, 50/60 Hz, Intermittent Pilot	BC7000L, PM720L

^aESP—Energy Saving Prepurge

7800 SERIES Required Components

Q7800A,B 22-Terminal Universal Wiring Subbases

Universal burner, panel or Wall mount subbases for RM78xx and EC78xx SERIES relay modules and S7830A Expanded Annunciator.

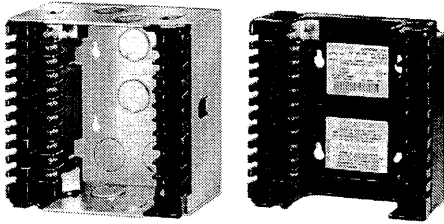

- Makes electrical connections for 7800 SERIES relay modules or S7830A Expanded Annunciator through bifurcated contacts.
- Provides terminals for field wiring.
- Q7800B has knockouts provided in back, top and bottom for conduit connections.
- Twenty-two terminals.

APPROVAL BODIES:

Underwriters Laboratories Inc. component recognized (Q7800A).

Underwriters Laboratories Inc. listed (Q7800B).
Canadian Standards Association certified.

DIMENSIONS:

Q7800A: 4-31/32 in. [126 mm] wide, 4-31/32 in. [126 mm] high, 1-13/32 in. [36 mm] deep.

Q7800B: 4-31/32 in. [126 mm] wide, 4-31/32 in. [126 mm] high, 2-7/32 in. [56 mm] deep.

REPLACEMENT PART 221779 Electrical Access Slot Covers.

Order Number	Description
Q7800A1005	Universal wiring subbase, panel mounting.
Q7800B1003	Universal wiring subbase, burner/wall mounting.
Q7800B1011	Universal wiring subbase, burner/wall mounting.

R7847, R7848, R7849, R7886 Flame Signal Amplifiers

Solid state plug-in amplifiers that respond to flame detector inputs to indicate the presence of flame when used with RM78xx and EC78XX SERIES relay modules.

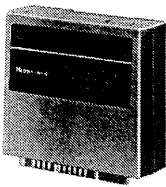

- Flame failure response time of 0.8 or 3 seconds.
- Flame signal strength ranges from 0.0 to 5.0 Vdc.
- Plug-in to 7800 relay module through printed circuit board edge card connector keyed for proper orientation.
- Flame signal test jacks to measure amplifier flame signal voltage.
- Country tests flame amplifier during burner operation; 7800 SERIES relay module locks out on safety shutdown with amplifier failure.

- R7847C Dynamic Self-Check Rectification Amplifier and R7886A Dynamic Self-Check Ultraviolet Amplifier test electronic components in the flame detection system 10 to 12 times per minute; 7800 SERIES relay module locks out on

APPROVAL BODIES:

Underwriters Laboratories Inc. listed.
Canadian Standards Association certified.
Factory Mutual approved.
Industrial Risks Insurers acceptable.

DIMENSIONS: 3-9/16 in. [91 mm] wide, 3-3/8 in. [85 mm] high, 7/8 in. [23 mm] deep.

WEIGHT: 2.5 oz.

OPERATING AMBIENT TEMPERATURE RANGE: - 40 F to +140 F [-40C to +60 C].

OPTIONAL COMPONENTS:

123514A Rectification Flame Simulator.

203659 Ultraviolet Flame Simulator.

7800 SERIES Required Components

R7B47, R7846, R7649, R7886 continued

FLAME DETECTION SYSTEMS

Plug-in Flame Signal Amplifiers						Applicable Flame Detectors		
Order Number	Type	Color	Self-Checking	Flame Failure Response Time	Fuel	Type	Models	
R7824C1002	Rectification	Green	Dynamic SELF CHECK	3.0 sec.	Gas, oil, coal	Ultraviolet (Purple Peeper)	C7024E, F.	
R7847A1025 R7847A1074 ¹			No	1.0 sec. or 0.8 sec. ⁹	Gas	Rectifying Flame Rod Holder	C7004, C7007, C7011 ^d , Complete assemblies: C7008, C7009, Q179.	
R7847A1033 R7847A1082 ¹				2.0 sec. or 3.0 sec. ⁹	Gas, oil, coal	Ultraviolet (Purple Peeper)	C7012A, C.	
R7847B1023 ² R7847B1064 ¹			Dynamic AMPLI-CHECK™	1.0 sec. or 0.8 sec. ⁹	Gas	Rectifying Flame Rod Holder	C7004, C7007, C7011 ^d , Complete assemblies: C7008, C7009, Q179.	
R7847B1031 ¹ R7847B1072 ¹				2.0 sec. or 3.0 sec. ⁹	Oil	Rectifying Flame Rod Holder, Photocell, or Ultraviolet (Purple Peeper)	C7004, C7007, C7011 ^d , Complete assemblies: C7008, C7009, Q179, C7003, C7010, C7013, C7014, C7012A, C.	
R7847C1005 ³			Dynamic SELF CHECK		Gas, oil, coal	Ultraviolet (Purple Peeper)	C7012E, F.	
R7848A1008 R7848B1006			Infrared	Red	No			Infrared (Lead Sulfide)
	Dynamic AMPLI-CHECK™					C7015.		
R7849A1015	Ultra-violet	Purple	No	1.0 sec. or 0.8 sec. ⁹	Gas, oil	Ultraviolet (Minipeeper)	C7027, C7035, C7044 ⁴	
R7849A1023				2.0 sec. or 3.0 sec. ⁹				
R7849B1013			Dynamic AMPLI-CHECK™	1.0 sec. or 0.8 sec. ⁹				
R7849B1021				2.0 sec. or 3.0 sec. ⁹				
R7861A1026			Dynamic SELF CHECK					
R7861A1034				0.8 sec. or 1.0 sec. ⁹				
R7886A1001		Blue		2.0 sec. or 3.0 sec. ⁹			Gas, oil, coal	Ultraviolet (Adjustable Sensitivity)

^aR7849A and C7027, C7035 and C7044 Flame Detectors should be used only on burners that cycle on-off at least once every twenty-four hours. Appliances with burners that remain on for twenty-four hours continuously or longer should use C7061 A Flame Detector with R7861A Amplifier.

^bCircuitry tests all electronic components in flame detection system (amplifier and detector) 12 times a minute during burner operation and shuts down burner if detection system fails.

^ccircuitry tests flame signal amplifier at least 12 times a minute during burner operation and shuts down burner if amplifier fails.

^dSee instructions for holder.

^eUse only Honeywell Photocell, part number 38316.

^fFor application requiring higher flame signal strength due to leadwire runs of greater than 50 feet or 15 meters.

⁹The 7800 series amplifiers have been modified as of 1/15/98 to provide 0.8 sec/1.0 sec., or 2.0 sec/3.0 sec.

FLAME FAILURE RESPONSE TIME ON RM or EC78XX DEVICES

Relay Module	Flame Failure Response Time (FFRT)	
	0.8 or 1.0 sec.	2.0 or 3.0 sec.
EC/RM7810. 7820,7830,7850	1.0	2.0
EC/RM7823, 7885, 7890, 7895, 7896, 7888, 7838, 7800, 7840	0.8	3.0
RM7824	NA	3.0

7800 SERIES Required Components

ST7800A Plug-In Purge Timer Card

Provides prepurge timing for select RM78xx and EC78xx SERIES relay modules.



Order Number	Prepurge Timing	Used With
ST7800A1005	2 seconds	RM7800, RM7838, RM7840, RM7888, RM7895, EC7800, EC7810, EC7820, EC7830, EC7840, EC7850, EC7888, EC7895 Relay Modules.
ST7800A1013	7 seconds	
ST7800A1021	10 seconds	
ST7800A1039	30 seconds	
ST7800A1047	40 seconds	
ST7800A1054	60 seconds	
ST7800A1062	90 seconds	
ST7800A1070	2.5 minutes	
ST7800A1088	4.0 minutes	
ST7800A1096	6.0 minutes	
ST7800A1104	9.0 minutes	
ST7800A1112	12.0 minutes	
ST7800A1120	15.0 minutes	
ST7800A1138	22.0 minutes	
ST7800A1146	30.0 minutes	

S7810A DATA CONTROLBUS MODULE™

Supports remote mounting of S7800 Keyboard Display Module, personal computer communications interface and remote reset.

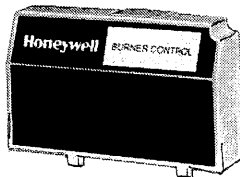

- Use with remotely mounted S7800 Keyboard Display Module.
- Installs directly on the front of 7800 SERIES relay modules.
- Provides communications bus interface and remote reset.

DIMENSIONS: 4-27/32 in. [123 mm] wide, 2-29/32 in. [73 mm] high, 29/32 in. [23 mm] deep.

WEIGHT: 4 oz.

OPERATING AMBIENTTEMPERATURE RANGE: -40 F to +140 F [-40 C to +60 C].

ELECTRICAL RATINGS: 13 Vdc peak full-wave rectified (+20/-15%).

OPTIONAL COMPONENTS: 203968A Remote Display Power Supply, plug-in.

REPLACEMENT PART:

203541 ControlBus 5-Wire Electrical Connector.

Order Number	Description	Used With
S7810A1009	Remote mounting of keyboard display module, personal computer communications interface and remote reset.	7800 SERIES Relay Modules.

7800 SERIES Optional Components

S7800A Keyboard Display Module

Provides current status of burner sequence, timing information, hold information and lockout information, as well as selectable or preemptive messages.



- Application flexibility.
- Communication interface capability.
- Dependable long-term operations provided by microcomputer technology.
- First out annunciation and system diagnostics provided by 2 row by 20 column Vacuum Fluorescent Display (VFD).
- Local or remote annunciation of operation and fault information.
- Optional first out expanded annunciation with 24 limit and interlock LEDs enhances keyboard display module information.
- Provides burner controller data.
- Remote reset.
- Report generation.

APPROVAL BODIES:
Underwriters Laboratories Inc. listed.

Canadian Standards Association certified.
Factory Mutual approved.
Industrial Risks Insurers acceptable.
Federal Communications Commission, Part 15, Class B.

DIMENSIONS: 4-27/32 in. [123 mm] wide, 2-29/32 in. [73 mm] high, 29/32 [23 mm] deep.

WEIGHT: 4 oz.

OPERATING AMBIENT TEMPERATURE RANGE: -40 F to +140 F [-40 C to +60 C].

ELECTRICAL RATINGS:

Voltage and Frequency 13 Vdc peak fullwave rectified (+20/-15%)

OPTIONAL COMPONENTS:

S7810A1009 DATA CONTROLBUS MODULE.

203541 ControlBus 5-Wire Electrical Connector.

203765 Remote Display Mounting Bracket.

203968A Remote Display Power Supply (plug-in).

203969A Remote Display Power Supply (screw terminal).

221818A Extension Cable Assembly to remote mount keyboard display module. 60 inch cable.

221818C Extension Cable Assembly.

120 inch cable.

Order Number	Description	Used With
S7800A1001	English Language Keyboard Display Module	RM7800, RM7823, RM7824, RM7838, RM7840, RM7885, RM7888, RM7890, RM7895 Relay Modules EC7810, EC7820, EC7823, EC7830, EC7850
S7800A1035	French Language Keyboard Display Module	
S7800A1043	German Language Keyboard Display Module	
S7800A1050	Italian Language Keyboard Display Module	
S7800A1068	Spanish Language Keyboard Display Module	
S7800A1118	Katakana (Japanese) Language Keyboard Display Module	
S7800A1126	Portuguese Language Keyboard Display Module	
S7800B1009	Chinese Language Keyboard Display Module - Remotely Mounted	

7800 SERIES Relay Modules

NEW!

RM7888A Semi-Automatic Industrial Primary Control

Microprocessor-based integrated burner control for industrial process semi-automatically fired gas, oil, coal, or combination fuels for single and multiple burner applications. Provides level of safety, functional capability and features beyond conventional controls.

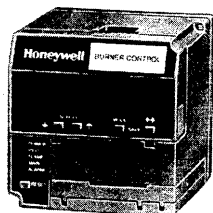

- Functions include automatic burner startup sequencing, five user selectable run sequences, four line-voltage sequence control inputs, flame supervision, system status indication, system or self-diagnostics and troubleshooting.
- Requires a relay module, subbase, and amplifier for operation.
- Options include PC interface, keyboard display module, DATA CONTROLBUS MODULE™, remote display mounting, first-out expanded annunciator, and COMBUSTION SYSTEM MANAGER™ software.
- Use with master system control which determines purge timing and confirms air supply and air flow.
- Nonvolatile memory retains history files and sequencing status after power loss.
- Optional remote reset capability.
- Five LEDs provide sequence information.
- Interchangeable plug-in flame amplifiers.
- Local or remote annunciation of operation and fault information.

APPROVAL BODIES:

Underwriters Laboratories Inc. Component Recognized.
Factory Mutual Approved.

Canadian Standards Association certified.

APPROXIMATE DIMENSIONS: 5 in. [127 mm] wide; 5 in. [127 mm] high; 5¼, in. [133 mm] deep with Q7800A Subbase, 6-3/32 in. [155 mm] deep with Q7800B Subbase.

WEIGHT: 1 lb., 10 oz. [737 grams].

OPERATING AMBIENT TEMPERATURE RANGE: -40 F to +140 F [-40 C to +60 C].

ELECTRICAL RATINGS:

Voltage and Frequency: 120 Vac (+10/-15%), 50 or 60 Hz (±10%).

REQUIRED COMPONENTS:

Q7800A or B Universal Wiring Subbase.
R7847, R7848, R7849, or R7886 Plug-in Flame Signal Amplifier.

OPTIONAL COMPONENTS:

A78001002 Tester.
Q7700A1014 Communications Interface Base Unit.
QS7800A1001 Communications Interface ControlBus Module.
S7800A1001 Keyboard Display Module.
S7810A1009 DATA CONTROLBUS MODULE™.
S7820A1007 Remote Reset Module.
S7830A1005 Expanded Annunciator.
ZM7850A1001 COMBUSTION SYSTEM MANAGER™ (CSM™).
123514A Rectifying Flame Simulator.
203541 ControlBus 5-Wire Electrical Connector.
203659 Ultraviolet Flame Simulator.
203765, 205321B, 204718A, B Remote Display Mounting Brackets.
203968A Remote Display Power Supply (13 Vdc) Plug-in.
221818A Sixty-inch Extension Cable Assembly.
221818C 120 inch Extension Cable Assembly.

SEQUENCE TIMING FOR NORMAL OPERATION:

RM7888A Sequence	Initiate	Standby	Purge	Pilot Flame Establishing Period	Main Flame Establishing Period	Pilot Relight	Run
Pilot: PV Return	10 sec.	a	b	10 sec.	15 sec.	5 sec. to infinity	a
Pilot: MV LoFire				—			
DSI Normal				4 sec.		—	
DSI High/Low Stepfire				—		—	
DSI On/Off Stepfire				—		—	

a STANDBY and RUN can be an infinite time period.

b PURGE time is determined by the system master controller.

Order Number	Description
RM7888A1019	Semi-automatic relay module, 50/60 Hz.

NEW!
S7810B MULTI-DROP SWITCH MODULE

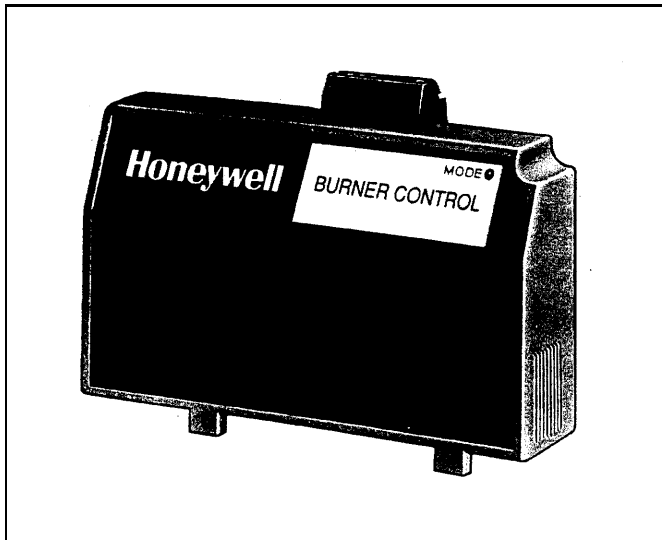

- Multi-dropped communications bus interface.
- Remote reset.
- Ability to remotely mount a Keyboard Display Module.
- SYSNet™ system compatible.

APPLICATION

The Honeywell 7800 SERIES is a microprocessor-based integrated burner control for automatically fired gas, oil or combination fuel single-burner applications. The 7800 SERIES is programmed to provide a level of safety, functional capability and features beyond the capacity of conventional controls. Functions provided by the 7800 SERIES include automatic burner sequencing, flame supervision, system status indication, system or self-diagnostics and troubleshooting.

The S7810B Multi-Drop Switch Module supports remote mounting of a Keyboard Display Module, personal computer communications interface for multi-dropped 7800 SERIES subnetworks, and remote reset of a 7800 SERIES Relay Module.

SPECIFICATIONS

Model:
 S7810B Multi-Drop Switch Module.

Electrical Ratings:

Voltage and Frequency:
 13 Vdc peak full-wave rectified (+20/-15%).
 Power Dissipation:
 2W maximum.

Terminal Ratings:

Power: 13 Vdc peak full-wave rectified.
 Earth ground.
 Local ControlBus (1,2,3) and Multi-Drop ControlBus (6,7,8):
 5 Vdc at 1 mA maximum.

Electrical Connector (included):

ControlBus: 208727 8-pin electrical connector,

Environmental Ratings:

Ambient Temperature:
 Operating: -40°F to +140°F (-40°C to +60°C).
 Storage: -40°F to +150°F (-40°C to 66°C).
 Humidity:
 85% relative humidity continuous, noncondensing.
 Vibration:
 0.5G environment.

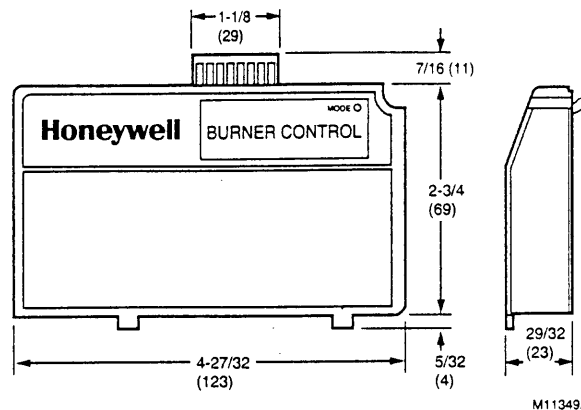

Fig. 1. Mounting dimensions of S7810B Multi-Drop Switch Module in in. (mm).

Weight:
 4 ounces.

Accessory:
 208727 eight-pin electrical connector.

Order Number	Description	Used With
S7800B1007	Dedicated Data Link (DDL) Driver Module provides Multidropping Cap of 7800 Series Relay Module. Enables Remote Display to be Mounted & Powered for Operation from remote location w/o a user interface.	7800 Series Relay Modules

7800 SERIES Optional Components

S7820A Remote Reset Module

Serves as link between remote reset pushbutton and relay module. Allows RM78xx and EC78xx SERIES relay modules to be reset from a remote location.

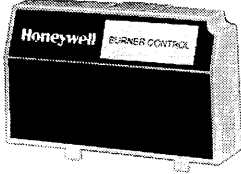

- Allows resetting of 7800 SERIES relay module by a remote reset pushbutton up to 1000 feet away.
- Installs directly on the front of 7800 SERIES relay module.

DIMENSIONS: 4-27/32 in. [123 mm] wide, 2-29/32 in. [73 mm] high, 29/32 in. [23 mm] deep.

WEIGHT 3 oz.

OPERATING AMBIENT TEMPERATURE RANGE: -40 F to +140 F [-40 C to +60 C].

REPLACEMENT PART: 203541 ControlBus 5-Wire Electrical Connector.

Order Number	Description	Used With
S7820A1007	Remote reset module to reset 7800 SERIES relay module.	7800 SERIES relay modules

S7830A First-Out Expanded Annunciator

Microprocessor-based expanded annunciator to support the RM78xx and EC78XX SERIES relay modules for first-out annunciation, sequencing, system or self-diagnostics and troubleshooting.

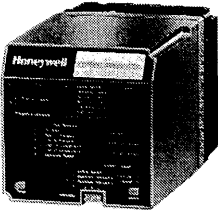

- Twenty-six Light Emitting Diodes (LEDs).
- Twenty-two LEDs to annunciate Limits and Interlocks.
- Four LEDs to annunciate Power, Current Status, First-out Status and System Lockout.
- Enhances S7800A Keyboard Display Module sequence hold and lockout messages.

- On/Off status of limits and interlocks.

- RS485 connection to 7800 SERIES relay module.

- Used with Q7800A,B subbases; 7800 SERIES relay modules.

APPROVAL BODIES:

Underwriters Laboratories Inc. listed.

Canadian Standards Association certified.

Order Number	Dimensions	Weight	Electrical Input
S7830A1005	5 in. [127 mm] wide, 5 in. [127 mm] high, 3-1/32 in. [77 mm] deep.	1 lb., 13 oz. [829 g].	120 Vac, 50/60 Hz

Q7700A, B Network Interface Unit

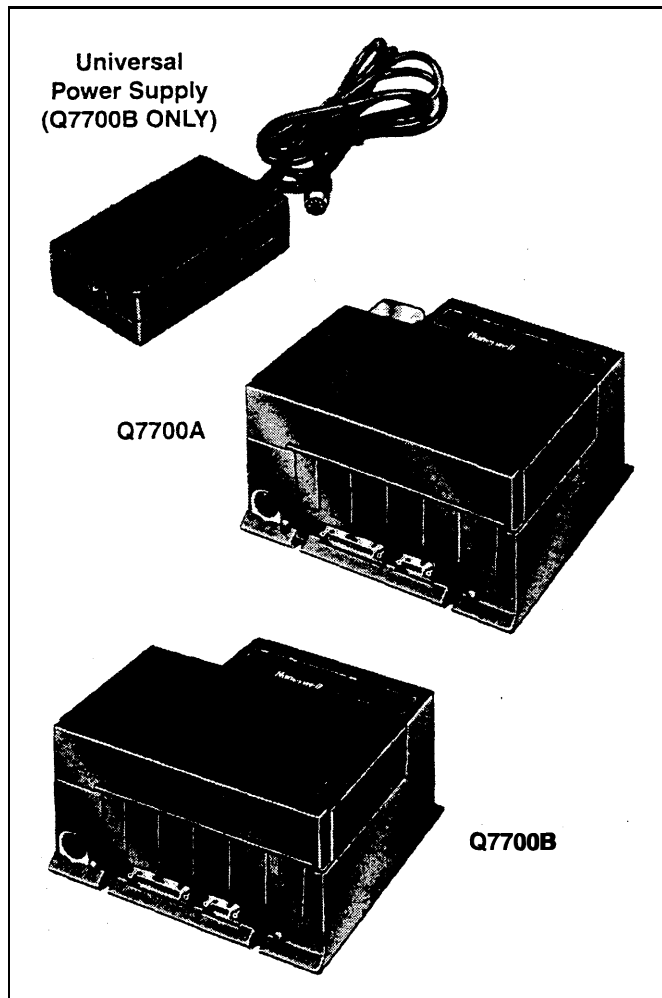

FEATURES

- Connect up to six BCS 7700 controls, Armstrong TrapScan™ systems, Pulsafeeder PULSAtrol™ systems, up to 900 QM40XX Data Acquisition Modules, and up to 222 multi-dropped 7800 SERIES devices or combinations of the systems.
- Local and remote annunciation of BCS 7700,7800 SERIES safety shutdowns and Armstrong TrapScan™, Pulsafeeder PULSAtrol™ and QM40XX Data Acquisition Alarms.
- Autodial-out on BCS 7700,7800 SERIES, Armstrong TrapScan™, Pulsafeeder PULSAtrol™, and QM40XX Data Acquisition Alarms for up to three telephone numbers.
- Personal computer user-friendly, menu driven, Microsoft® Windows™ software-based user interface.
- On-line data logging.
- Modular construction.
- Access controlled with password protection.
- Light Emitting Diode (LED) status interface.
- 19,200 selectable baud personal computer/printer interface.
- 19,200 selectable baud modem interface. Interfaces with Hayes-compatible modems.
- Fault-dating and time -stamping internal software clock.
- Dial-out override for maintenance-induced alarms.
- Dedicated RS-232 external modem port.
- Universal power supply (Q7700B only).
- SYSNet™ compatible.

APPLICATION

The Q7700A,B Network Interface Unit provides local and remote monitoring and diagnostics of the BCS 7700, 7800 SERIES, Armstrong TrapScan™, Pulsafeeder PULSAtrol™ and QM40XX Data Acquisition devices with an IBM® equivalent personal computer. The Q7700 also provides local and remote configuration and control of BCS 7700, Pulsafeeder PULSAtrol™, or QM40XX Data Acquisition devices.

APPROVAL BODIES:

Underwriters Laboratories Inc. component recognized.
 Canadian Standards Association certified.
 Factory Mutual approved.
 Industrial Risk Insurers acceptable.
 Federal Communications Commission: Part 15, Class A - Emissions.
 Canadian Department of Communications certified.

OPERATING AMBIENT TEMPERATURE RANGE: 32 F to 130 F [0 C to 54 C].

HUMIDITY: 85% relative humidity continuous, noncondensing.

COMPONENTS:

221237 Cover Assembly, Baser Unit.
 221240 Cover Assembly, Electrical Enclosure.
 202433 Slot Inserts, ControlBus Slots.
 200603 ControlBus Module 3-Wire Electrical Connector.
 203541 ControlBus Module 5-Wire Electrical Connector.
 QS7700A Communications Interface ControlBus Module (BCS7700).
 QS7800A Communications Interface ControlBus Module (7800 SERIES).

QS7850A General Purpose Interface ControlBus Module.

ACCESSORIES:

QM4520A: RS-232C to RS-485 Converter.
 QS7800B: ControlBus™ Module for multi-drop 7800 Series.
 QS7800C: ControlBus™ Module for QM40XX Data Acquisition modules.
 QS7800D: ControlBus™ Module for Armstrong Trap Scan™.
 QS7800E: ControlBus™ Module for Pulsafeeder PULSAtrol™.
 ZM7850A: Combustion System Manager® Software for personal computer.
 ZM7850B: SYSNet™ Operator Interface Software for personal computer.
 200603: ControlBus™ Module Electrical Connector.
 202433: Slot Inserts, ControlBus™ Slots.
 221237/1698: Cover Assembly, Base Unit.
 221240/1698: Cover Assembly, Electrical Enclosure.
 Null Modem Adaptor (obtain locally).
 209164: Power Supply, panel mounting, 85 to 132 Vac or 170 to 264 Vac input voltage, switchable; 1.4A maximum input current; 24 Vdc (±10%) output voltage; 3A maximum output current.
 209162 Power Supply, DIN-Rail mounting, 110 Vac input voltage; 225mA input current; 24 Vdc (±1%) output voltage; 1A output current.
 209163 Power Supply, DIN-Rail mounting, 220 Vac input voltage; 225mA input current; 24 Vdc (±1%) output voltage; 1A output current.
 208670; IEC 120V power cord for universal power supply (obtain other plug configuration locally).
 208289: Universal Power Supply, 100 to 250 Vac, 50/60 Hz.

Order Number	Dimensions	Weight	Electrical Ratings	Electrical Connectors	Signal Characteristics	Direct Terminal Hookup
Q7700A1014	9 in. [229 mm] wide, 8 in. [203 mm] high, 4-7/8 in. [123 mm] deep.	4 lbs., 10 oz.	Voltage and Frequency: 120 Vac (+10/-15%), 60 Hz (±10%) ControlBus Communication: RS485	RS232C Port 25 "D" pin connector; Local communications. Remote	Selectable baud rate up to 19,200	RS232C Connection, PINS. 1 Ground: Protective. 2 Transmit Data (TD). 3 Receive Data (RD). 7 Ground: Signal.
Q77C0B1004		5 lbs., 13 oz.	100-250 Vac, 50/60 Hz Power Supply (part number 208289 included)	communications requires an external modem.		

SPECIFICATIONS

Models:

Q7700A,B Network Interface Unit:

Q7700A1014 Network Interface Unit, 120 Vac only.

Q7700B1004 Network Interface Unit with Universal 100 to 250 Vac power supply.

NOTE: 208670 Power Cord provided with 208289 Universal 100 to 250 Vac Power Supply is equipped with a standard U.S. 120 Vac plug. Adapter plugs for other power systems, if needed, can be obtained locally.

Electrical Ratings:

Voltage and Frequency:

Q7700A: 120 Vac (+10%/-15%), 50/60 Hz.

Q7700B: 100 to 250 Vac, 50/60 Hz.

Universal Power Supply (Q7700B only):

Rated Voltage: 100 to 250 Vac, 50/60 Hz.

Rated Input: 0.7A to 0.3A.

Secondary Voltages: +5V, +12V, -12V.

Secondary Current: 4.0A, 1.0A, 0.6A maximum.

Electrical Connectors:

RS-232C port, 25 D pin connector for local communications.

RS-232 port, 9 D pin connector for remote communications.

Environmental Ratings:

Ambient Temperature:

Operating: 32°F to 130°F (0°C to 54°C).

Storage: -30°F to +150°F (-34°C to 66°C).

Humidity:

Operating, 85 percent relative humidity, continuous, noncondensing.

Vibration:

Continuous 0.5G.

Enclosure:

NEMA 1.

Dimensions:

See Fig. 1.

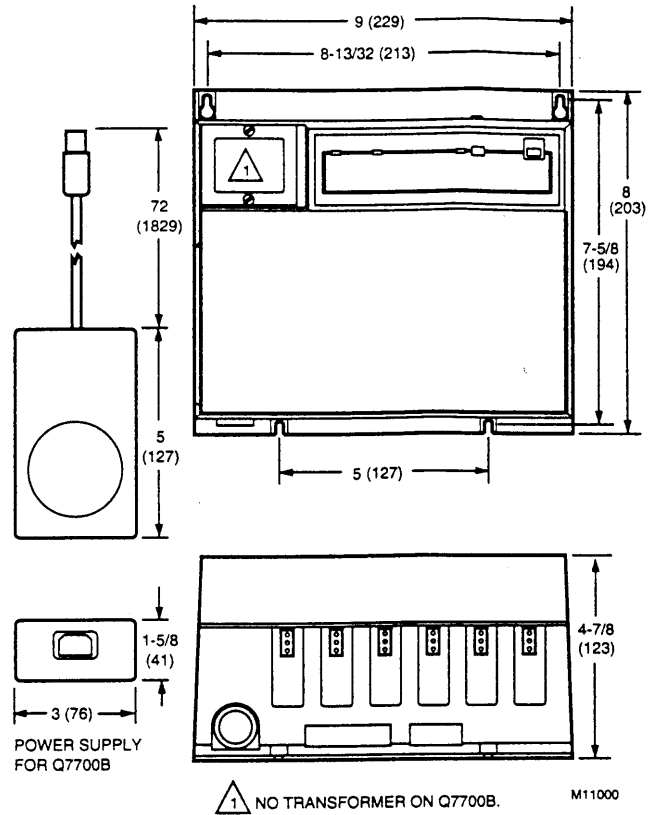

Fig. 1. Network Interface unit dimensions in in. (mm).

Weight:

Q7700A: 4 lb, 5 oz unpacked, without ControlBus™ Modules.

Q7700B: 5 lb. 13 oz unpacked, including power supply and cord, without ControlBus™ Modules.

Approvals:

Underwriters Laboratories Inc: File No. MP268, Guide No. MCCZ2.

Canadian Standards Association: LR95329.

Factory Mutual: J.1. 2Q2A5.AF.

7800 SERIES Communications

QS7800A/QS7850A Communications Interface ControlBus Module

Allows remote monitoring and diagnostics of the RM78xx and EC78xx SERIES relay modules with an IBM® compatible personal computer.

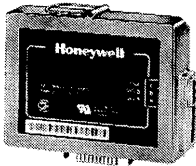

- Provides local and remote annunciation of 7800 SERIES faults.
- QS7850A provides open protocol communications with third party systems.
- Provides user interface to personal computer.
- Modular construction, NEMA #1 rated enclosure.

APPROVAL BODIES:

Underwriters Laboratories Inc. component recognized, File No. MP268, Guide No. MCCZ2.
 Canadian Standards Association certified, LR80141.
 Federal Communications Commission, Part 15, Class A-Emissions, Part 68; registered.
 FCC Registration Number HS92SJ-10735-D-T-E.
 Canadian Department of Communications certified.

DIMENSIONS: 4-21/32 in. [118 mm] wide, 3-29/32 in. [99 mm] high, 1 in. [25 mm] deep.

WEIGHT 8 oz.

OPERATING AMBIENT TEMPERATURE RANGE: 32 F to 130 F [0 C to 54 C].

ENCLOSURE: NEMA 1

ELECTRICAL RATING: RS485 ControlBus. Current Draw: 7 mA.

OPTIONAL COMPONENT:

200603 ControlBus Module 3-Wire Electrical Connector.

Order Number	Electrical Connectors Included	Used With
QS7800A1001	ControlBus three-prong electrical connector.	7800 SERIES relay modules.
QS7800B1000	Network Interface ControlBus Module for Multi-dropping up to 31 multi-dropped .7800 Series.	7800 SERIES Relay Modules S7810 Network Interface
QS7850A1006	ControlBus three-prong electrical connector.	Provides open communication with third party systems.
QS7800C1009	ControlBus three-prong electrical connector.	SYSNet™ Data Acquisition Modules.
QS7800D1008	Control Bus three-prong electrical connector.	Armstrong International Trapscan™ Trap Monitoring System.
QS7800E1007	ControlBus three-prong electrical connector.	Pulsafeeder PULSAtrol™ Surface Blowdown System.

ZM7850A Combustion System Manager™ Software

The ZM7850 is support software for connecting BCS 7700, RM78xx, and EC78xx SERIES controls with an IBM® or equivalent personal computer running Microsoft Windows™ 3.0 or greater. It is a graphical, mouse-driven software package that is easy to use and understand. It provides data logging, remote interrogation, remote set point adjustment of non-safety parameters (BCS 7700 only), history, real-time graphics, and control point trending.

and fault reporting for up to 6,000 individual burner/boiler controls.

Order Number	Description
ZM7850A1001	Combustion System Manager
ZM7850B1000	SYSNet™ Software to monitor Honeywell BBC Pulsafeeder Controls, Armstrong Traps & Adam Data Acq. modules. Microsoft windows based. Touch screen compatible faceplates, dynamic graphics, instrumentation & multi-media.

A matrix listing the O. S. numbers obsolete and their modified replacements if listed below:

Amplifiers Obsolete	Modified Replacement
R7847A1058	R7847A1025
R7847A1066	R7847A1033
R7847A1090	R7847A1074
R7847A1108	R7847A1082
R7847B1049	R7847B1023
R7847B1056	R7847B1031
R7847B1080	R7847B1064
R7847B1098	R7847B1072
R7849A1049	R7849A1015
R7849A1056	R7849A1023
R7849B1039	R7849BI013
R7849B1047	R7849B1021
R7861A1000	R7861A1034
R7861A1018	R7861A1026

A7800A Tester

Provides quick operational check of the 7800 SERIES System components.

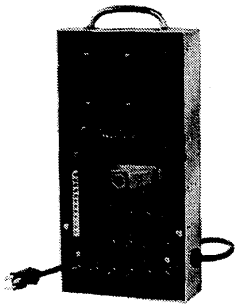

- Function switches and selectors simulate interlocks and control functions that allow 7800 SERIES devices to operate through sequences.
- Indicator lamps represent outputs as activated.

OPERATING AMBIENT TEMPERATURE RANGE: 0 F to 120 F
[-18 C to 49 C].

ELECTRICAL RATING: 120 Vac, 50/60 Hz.

REQUIRED COMPONENTS:

- 203579A Configuration plug for RM7800/RM7840.
- 203579B Configuration plug for RM7838A.
- 203579C Configuration plug for RM7838B.
- 203579D Configuration plug for RM7885.
- 203579E Configuration plug for RM7890.
- 203579F Configuration plug for RM7895.
- 203579G Configuration plug for RM7823.

OPTIONAL COMPONENTS:

- 123514A Rectification Flame Simulator.
- 203659 Ultraviolet Flame Simulator.
- W136A Test Meter.

REPLACEMENT PARTS: 192128 Panel fuse, 1.0A.

Order Number	Application
A7800A1002	Operational tests of 7800 SERIES relay modules.

7800 SERIES Accessories

Accessories

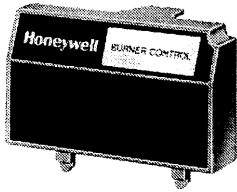

221729A



203968A

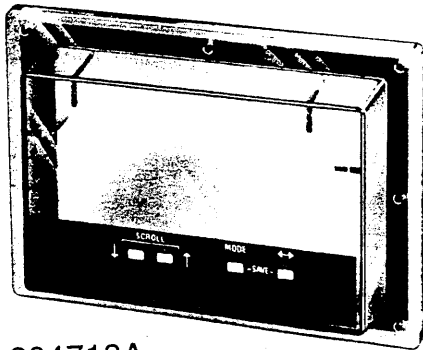
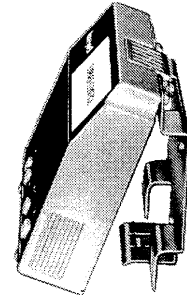

204718A



204718C

Description/Title	Part Number	Used With
ControlBus Module Electrical Connector	200603	QS7800
Electrical Access Slot Covers	221779	Q7800
Dust Cover	221729A	RM7800, RM7823, RM7824, RM7838, RM7840, RM7885, RM7888, RM7890, RM7895, EC7810, EC7820, EC7823, EC7830, EC7850 with S7800A
ControlBus 5-Wire Electrical Connector	203541	
Remote Display Mounting Bracket	203765	
Remote Display Power Supply (Plug-in) 13 Vdc	203968A	
Extension Cable Assembly for Remote Mounting Keyboard Display Module-60 in. Cable Length 120 in. Cable Length	221818A 221818C	
NEMA 4 Cover Assembly with Waterproof Gasket	204718A	
NEMA 4 Cover Assembly with Waterproof Gasket and provides remote reset of the 7800 series device	204718C	
Flush Mounting Bracket	205321B	

EC7800 SERIES EC7810A, EC7820A

Microprocessor-based integrated primary burner control for automatically fired gas, oil, or combination fuel single atmospheric (EC7810A) or atmospheric with fan (EC7820A) burner applications.

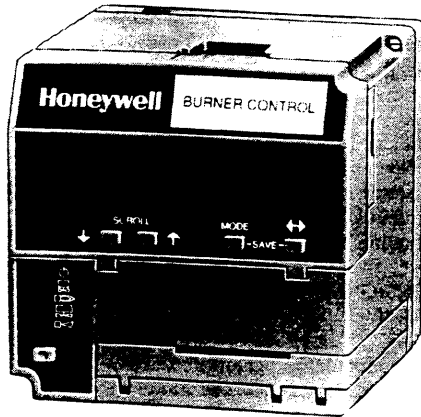

EC7810A, EC7820A

- Functions include automatic burner sequencing, flame supervision, system status indication, system or self-diagnostics and troubleshooting.
- Five LED's provide sequence information.
- Access for external electrical voltage checks.
- Interchangeable plug-in flame amplifier.
- Non-volatile memory retains history files and lockout status after loss of power.
- Spark Blind during pre-ignition.
- Ignition attempts: 1 or 5. Selectable by model numbers.

APPROVALS: This product complies with the following European directives:

- Gas Appliance Directive (90/269/EEG).
- Low Voltage Directive (73/23/EEG).
- EMC Directive (89/336/EEG).
- GASTEC (CE-63AP307011).
- CE Mark approval EN298 "Automatic gas burner systems for gas burners and gas burning appliances with or without fans".
- For oil applications, a German TUV approval, per EN230.

AUSTRALIAN APPROVAL: Australian Gas Association Code AG210 - Electronic flame safeguards and detectors - Certification number 5097 dated June, 1994. EC7810 and EC7820 Class 2C and lower applications.

MOUNTING: Q7800A for panel mount. To meet EN60730, the Relay Module has to be mounted in a secured panel which meets IP40 class of protection.

DIMENSIONS: 5 in (127mm) wide; 5 in. (127mm) high; 5 ¼ in. (133mm) deep with Q7800A1005 subbase.

WEIGHT:
Relay Module: 730 grams unpacked.
Keyboard Display Module: 113 grams unpacked.

OPERATING AMBIENT TEMPERATURE RANGE:
-40°C to +60°C (-40°F to +140°F)

ELECTRICAL RATING: Voltage and Frequency:
220-240 Vac (+10/-15%), 50/60 Hz (±10%).

REQUIRED COMPONENTS:
Q7800A1005 Universal Wiring Subbase.
R7847, R7849, R7861, R7886 Flame Signal Amplifier.
ST7800A Plug-in Purge Timer Card.

OPTIONAL COMPONENTS:
S7820 Remote Reset Module.

REPLACEMENT PARTS:
S7800A, B Keyboard display module: See page H-60.
S7810A1009 DATA CONTROLBUS MODULE™.
203541 5-Wire Electrical Connector to S7800A.
221729 Dust Cover.
203765 Remote Display Mounting Bracket.
221818A 1.5 Meter Extension Cable Assembly to Remote Mount Keyboard Assembly.
204718A NEMA4 Cover Assembly for S7800A.
204718C NEMA4 Cover Assembly with Reset for S7800A.

Order Number	Voltage	Initiate	Stand-by	Purge or Waiting	Pre-ignition	First Safety Time	Pilot Stab.	Main Trial Time***	Main Stab.	Run	Ignition Attempts
EC7810A1027	220-240 Vac 50/60 Hz	2 sec	*	**	3 sec	5or10 sec	5 sec	5or8 sec	5 sec	*	1
EC7810A1035	220-240 Vac 50/60 Hz	2 sec	*	**	3 sec	5or10 sec	5 sec	5or8 sec	5 sec	*	5
EC7820A1026	220-240 Vac 50/60 Hz	2 sec	*	**	3 sec	5or10 sec	5 sec	5or8 sec	5 sec	*	1
EC7810A1034	220-240 Vac 50/60 Hz	2 sec	*	**	3 sec	5or10 sec	5 sec	5or8 sec	5 sec	*	5

* STANDBY and RUN can be an infinite time period.

** Waiting Time will be determined by which ST7800A purge card is selected.

*** Second Safety Time is Main Trial Time plus Flame Failure Response Time.

EC7800 SERIES EC7830A, EC7850A

Microprocessor-based integrated burner control for automatically fired gas, oil, or combination fuel full modulation (EC7850A) or ON/OFF (EC7830A) power burner applications.

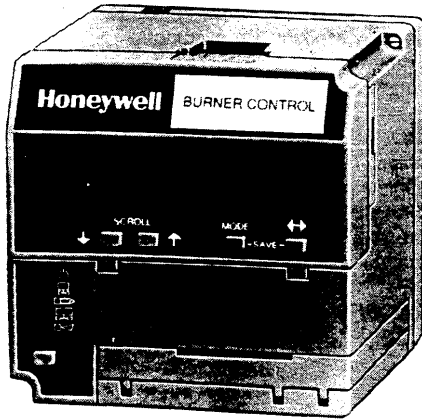

EC7830A, EC7850A

- Functions include automatic burner sequencing, flame supervision, system status indication, system or self-diagnostics and troubleshooting.
- Access for external electrical voltage checks.
- Five LED's provide sequence information.
- Five function Run/Test switch.
- Interchangeable plug-in flame amplifier.
- Non-volatile memory retains history files and lockout status after loss of power.
- Compatible with existing Honeywell flame detectors.
- Spark Blind during pre-ignition.

APPROVALS: This product complies with the following European directives:

- Gas Appliance Directive (90/269/EEG).
- Low Voltage Directive (73/23/EEG).
- EMC Directive (89/336/EEG).
- GASTEC (CE-63AP307011).
- CE Mark approval EN298 "Automatic gas burner systems for gas burners and gas burning appliances with or without fans".
- For oil applications, a German TUV approval, per EN230.

AUSTRALIAN APPROVALS: Australian Gas Association Code AG210 - Electronic flame safeguards and detectors - Certification number 5097 dated June, 1994. EC7830 and EC7850 Class 1A or 2A applications.

MOUNTING: Q7800A1005 for panel mount. To meet EN60730, the Relay Module has to be mounted in a secured panel which meets IP40 class of protection.

DIMENSIONS: 5 in (127mm) wide; 5 in. (127mm) high; 5 1/4 in. (133mm) deep with Q7800A1005 subbase.

WEIGHT:

Relay Module: 730 grams unpacked.
Keyboard Display Module: 113 grams unpacked.

OPERATING AMBIENT TEMPERATURE RANGE:

-40°C to +60°C (-40°F to +140°F)

ELECTRICAL RATING: Voltage and Frequency: 220-240 Vac (+10/-15%), 50/60 Hz (±10%).

REQUIRED COMPONENTS:

Q7800A1005 Universal Wiring Subbase.
R7847, R7849, R7861, R7886 Flame Signal Amplifier.
ST7800A Plug-in Purge Timer Card.

OPTIONAL COMPONENTS:

S7820 Remote Reset Module.

REPLACEMENT PARTS:

S7800A, B Keyboard display module: See page H-60.
S7810A1009 DATA CONTROLBUS MODULE™.
203541 5-Wire Electrical Connector to S7800A.
221729 Dust Cover.
203765 Remote Display Mounting Bracket.
221818A 1.5 Meter Extension Cable Assembly to Remote Mount Keyboard Assembly.
204718A NEMA4 Cover Assembly for S7800A.
204718C NEMA4 Cover Assembly with Reset for S7800A.

Order Number	Voltage	Initiate	Stand-by	Purge or Waiting	Pre-ignition	First Safety Time	Pilot Stab.	Main Trial Time***	Main Stab.	Run	Post Purge
EC7830A1033	220-240 Vac 50/60 Hz	2 sec	*	**	3 sec	3 or 5 sec	5 sec	3 or 5 sec	5 sec	*	2 sec
RM7830A1003	120 Vac 50/60 Hz	2 sec									
EC7830A1041	220-240 Vac 50/60 Hz	2 sec	*	**	3 sec	3 or 5 sec	5 sec	3 or 5 sec	5 sec	*	30 sec
RM7830A1011	120 Vac 50/60 Hz	2 sec									
EC7830A1066	220-240 Vac 50/60 Hz	2 sec	*	**	3 sec	3 or 5 sec	5 sec	3 or 5 sec	5 sec	*	15 sec
RM7830A1029	120 Vac 50/60 Hz	2 sec									
EC7850A1064	220-240 Vac 50/60 Hz	2 sec	*	**	3 sec	3 or 5 sec	5 sec	3 or 5 sec	5 sec	*	Dynamic Damper Check 30 sec
EC7850A1072	220-240 Vac 50/60 Hz	2 sec	*	**	3 sec	3 or 5 sec	5 sec	3 or 5 sec	5 sec	*	2 sec
RM7850A1001	120 Vac. 50/60 Hz	2 sec									
EC7850A1080	220-240 Vac 50/60 Hz	2 sec	*	**	3 sec	3 or 5 sec	5 sec	3 or 5 sec	5 sec	*	30 sec
RM7850A1027	120 Vac 50/60 Hz	2 sec									
EC7850A1122	220-240Vac 50/60 Hz	2 sec	*	**	3 sec	3 or 5 sec	5 sec	3 or 5 sec	5 sec	*	15 sec
RM7850A1019	120 Vac 50/60 Hz	2 sec									

- * STANDBY and RUN can be an infinite time period.
- ** Waiting Time will be determined by which ST7800A purge card is selected.
- *** Second Safety Time is Main Trial Time plus Flame Failure Response Time.