

V5055A-E Industrial Gas Valves

PRODUCT DATA

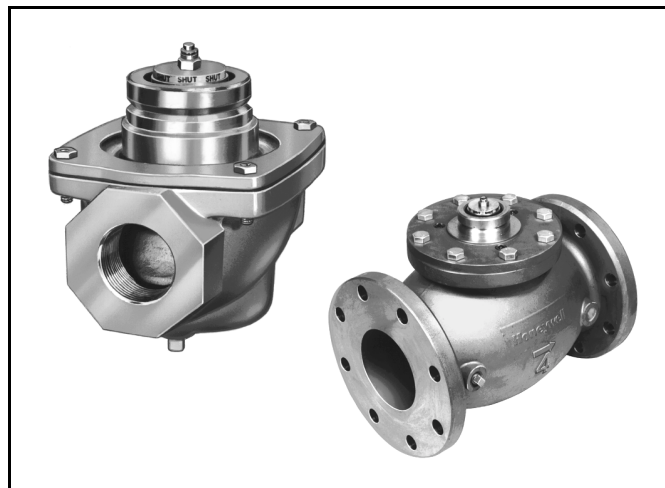

APPLICATION

The V5055 Gas Valves are used with the V4055, V4062, and V9055 Fluid Power Actuators to control gas flow to commercial and industrial burners.

FEATURES

- Used with natural or liquefied petroleum (LP) gases.
- V5055 normally closed valves are rated for final shutoff service (safety shutoff).
- V5055A,C,D,E Valves are for On-Off service.
- V5055B Valve has a characterized guide and in combination with the V4055, V4062, and V9055 Fluid Power Actuators, provides slow-opening, hi-lo-off, and modulating functions respectively.
- V5055C,E Valves have a double seal and are used with V4055D,E Actuators to provide proof-of-closure switch and valve seal overtravel interlock.
- V5055D,E Valves are for high pressure applications (see Table 1).
- Seven valve sizes from 3/4 to 3 inches have NPT threaded connections. Models are available with BSP-PL threads. V5055A,B,C Valves are available in a 4 inch size and have flange connections.
- Most models have 1/4 inch upstream and downstream top and plug. BSP-PL thread models have 1/4 inch upstream tap and plug.
- Valve body rating of 75 psi (517.1 kPa).
- Yellow SHUT indicator attached to the valve stem provides an indication of the valve closed position.
- Unpainted, die-cast aluminum body.

Contents

Application	1
Features	1
Specifications	2
Ordering Information	2
Gas Valve Sizing	5
To Size Two Identical Valves Piped In Series	5
Installation	7
Operation and Checkout	9
Service Information	11



SPECIFICATIONS

Models:

V5055A Industrial Gas Valve for On-Off service.
 V5055B Industrial Gas Valve with characterized guide for slow opening, HI-LO-OFF, or modulating service.
 V5055C: Same as V5055A but incorporates a double seal. Used with the V4055D Actuator to provide proof-of-closure switch and a valve seal overtravel interlock.
 V5055D: Same as V5055A but for high pressure applications.
 V5055E: Same as V5055C but for high pressure applications.

Type of Gas: Natural or liquefied petroleum (LP) only.

Pipe Size: 3/4, 1, 1-1/4, 1-1/2, 2, 2-1/2, 3, and 4 in. (only V5055A,B,C available in 4 in. size).

Pipe Threads: NPT or BSP-PL Threads (equivalent to ISO R7 and DIN 2999). Available on inlet and outlet of 3/4 to 3 inch valves. Four inch valves have flange connections.

Pressure Ratings: See Table 1.

Valve Body Rating: 75 psi (517.1 kPa).

Valve Capacities: A.G.A. ratings at 1 in. (0.25 kPa) pressure drop; based on gas with specific gravity of 0.64.

Table 1. Pressure Ratings of Valve-Actuator Combinations.

Valve	Actuator											
	V4055A,D ^a				V4055B,E ^a				V4062,V9055 ^a			
	Diff. ^b		Closeoff ^c		Diff. ^b		Closeoff ^c		Diff. ^b		Closeoff ^c	
	psi	kPa	psi	kPa	psi	kPa	psi	kPa	psi	kPa	psi	kPa
V5055A,C 3/4 to 3 in.	5	34.5	15	103.4	15	103.4	15	103.4	5	34.5	15	103.4
V5055A,C 4 in.	3	20.7	15	103.4	5	34.5	15	103.4	3	20.7	15	103.4
V5055B 3/4 to 3 in.	5	34.5	15	103.4	15	103.4	15	103.4	5	34.5	15	103.4
V5055B 4 in.	3	20.7	15	103.4	5	34.5	15	103.4	3	20.7	15	103.4
V5055D,E 3/4, 1, 1-1/4, 1-1/2 in.	5	34.5	75	517.1	25	172.4	75	517.1	5	34.5	75	517.1
V5055D,E 2, 2-1/2. 3 in.	5	34.5	45	310.3	15	103.4	45	310.3	5	34.5	45	310.3

^a Use a V4055D, V4055E, V4062D, or V9055D (with proof-of-closure switch) with a V5055C or E (with double seal) for valve seal overtravel interlock.

^b Maximum operating pressure differential.

^c Maximum close-off pressure without seal leakage. This is the maximum allowable pressure drop to which a valve may be subjected while fully closed, and is independent of the valve body rating.

Upstream Tapping and Plug: 1/4 in. NPT or BSP-PL is standard.

Downstream Tapping and Plug:
 1/4 in. NPT on most domestic models.
 1/8 in. NPT on V5055C1182.

Ambient Operating Temperature Rating:
 -40°F to 150°F (-40°C to 66°C); -40°F to 125°F (-40°C to 52°C) when used with V9055.

ORDERING INFORMATION

When purchasing replacement and modernization products from your TRADELINE® wholesaler or distributor, refer to the TRADELINE® Catalog or price sheets for complete ordering number.

If you have additional questions, need further information, or would like to comment on our products or services, please write or phone:

1. Your local Home and Building Control Sales Office (check white pages of your phone directory).
2. Home and Building Control Customer Relations
 Honeywell, 1885 Douglas Drive North
 Minneapolis, Minnesota 55422-4386 (800) 328-5111

In Canada—Honeywell Limited/Honeywell Limitée, 35 Dynamic Drive, Scarborough, Ontario M1V 4Z9.

International Sales and Service Offices in all principal cities of the world. Manufacturing in Australia, Canada, Finland, France, Germany, Japan, Mexico, Netherlands, Spain, Taiwan, United Kingdom, U.S.A.

Table 2. Valve Rated Capacity.

Valve Size (in.)	I.A.S. ^a Rated Capacity	
	cf/h	cu m/hr
3/4	665	18.8
1	960	27.2
1-1/4	1406	39.8
1-1/2	1717	48.6
2	3620	102.5
2-1/2	4250	120.3
3	5230	148.1
4 (V5055A)	10200	288.8
4 (V5055B,C)	9180	259.9

^a A joint venture of CGA Approvals Inc. and AGA Laboratories.

Material: Die-cast aluminum.

Mounting: Mounts directly in the gas supply line.

Dimensions: See Fig. 2 and 3.

Weight:

3/4, 1, 1-1/4, 1-1/2, in. valve: 4 lb. (1.8 kg).

2 in. valve: 8 lb. (3.6 kg).

2-1/2, 3 in. valve: 11 lb. (5.0 kg).

4 in. valve: 28 lb. (12.7 kg).

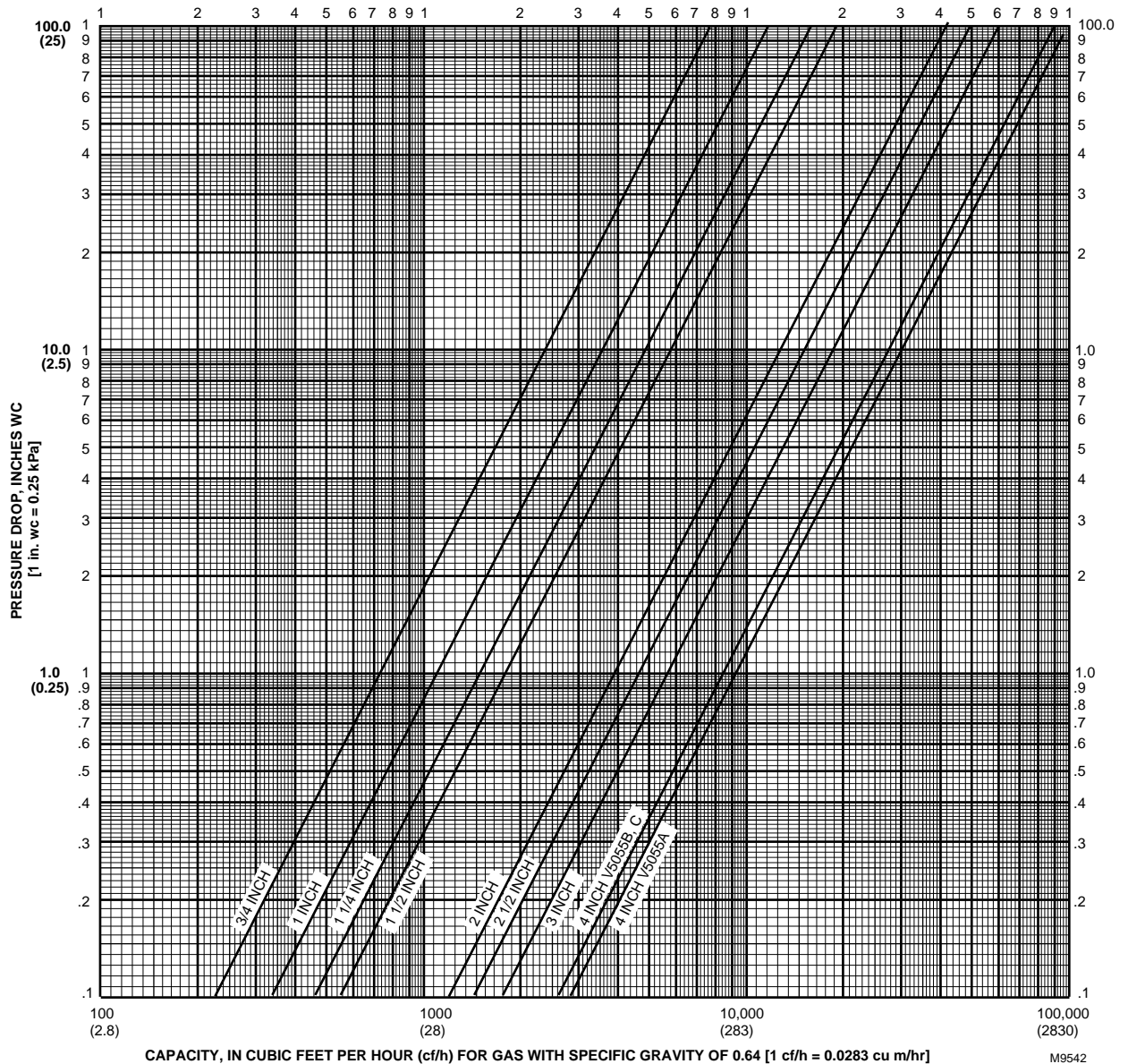

Fig. 1. Flow curves for V5055 Valves.

Replacement Parts:

Replacement Seal Assembly: Includes valve seal, bonnet seal, and tube of lubricant.

133393A: for 3/4, 1, 1-1/4, and 1-1/2 in. valves

133392A: for 2, 2-1/2, and 3 in. valves.

137253A: for 4 in. valves.

Replacement Bonnet Assembly: Includes complete bonnet assembly, plus the required replacement seal assembly. See Table 3.

Table 3. Replacement Bonnet Assemblies.

Valve Model	Valve Size (in.)	Replacement Bonnet Assembly
V5055A (On-Off)	3/4, 1, 1-1/4, 1-1/2	133398AA
	2, 2-1/2, 3	133417AA
	4	136911AA
V5055B (Characterized guide)	3/4, 1, 1-1/4, 1-1/2	133398BA
	2, 2-1/2, 3	133417BA
	4	136911BA
V5055C (Valve-closed indicator)	3/4, 1, 1-1/4, 1-1/2	137398CA
	2, 2-1/2, 3	133417CA
	4	136911CA
V5055D (High pressure On-Off)	3/4, 1, 1-1/4, 1-1/2	136308AA
	2, 2-1/2, 3	136307AA

Approvals:

The following combinations of V5055 Valves (3/4 through 4 in.) and V4055, V4062 and V9055 Fluid Power Actuators are approved by these agencies:

Underwriters Laboratories Inc. Listed: (File No. MH1639, Guide No. YIOZ):

V4055A,B,D,E/V5055A,B,C,D,E

V4062/V5055A,B,C,E

V9055/V5055A,B,C,E

Industrial Risk Insurers (Formerly F.L.A.) Acceptable:

V4055A,B,D,E/V5055A,B,C,D,E

V4062/V5055A,B,C,E

V9055/V5055A,B,C,E

Factory Mutual Approved (Report No. 20698, 20835, 21172, and 24061).

American Gas Association (IAS) Design Certified

(Report No. 21 -1 C):

V4055A/V4055A,B

V4055E/V5055E

V4055B/V5055D

V4062/V5055B,C

V4055D/V5055C

V9055/V5055B,C

NOTE: The IAS does not certify models equipped with BSP threads.

Canadian Gas Approvals Inc. (IAS) Certified

(Report No. 1029-SSV-4098, 60 Hz actuator models only):

V4055A,B,D,E/V5055A,B,C,D,E

V4062/V5055B

V9055/V5055B

British Gas Corporation and Dutch Gas Institute Approved:

V4055 or V4062 with V5055A1145, A1152, A1160,

A1178, B1168, B1184, B1192, B1200, B1218.

Australian Gas Association Approved:

V5055B1267, B1275, and B1291.

DIN-DVGW Approved (Germany):

V5055A1145, A1152, A1160, A1178, B1168, B1184,

B1192, B1200, and B1218.

GAS VALVE SIZING

1. Check the burner nameplate for (a) the type of gas used, and (b) the gas flow capacity. The capacity will be listed in Btu/h (Btus per hour) or in cf/h (cubic foot per hour).
2. Call the gas utility for information on (a) the specific gravity (sp gr) and (b) Btu per cubic foot (Btu/cu ft) for type of gas used.
3. Find the capacity in cf/h. If the capacity is listed in Btu/h, convert to cfh by the following formula:

$$\text{Capacity in cf/h} = \frac{\text{Btu/h (from burner nameplate)}}{\text{Btu/cu ft (from gas utility)}}$$

4. For gases with specific gravities other than 0.64, multiply the burner cfh by the proper conversion factor. See Table 4.

Table 4. Conversion Factors for LP—Propane and LP—Butane.

Type of Gas	sp gr (average)	Multiply cf/h by:
LP—Propane	1.53	0.647
LP—Propane	1.98	0.569

5. Use the corrected capacity in cf/h when determining the gas valve size in Fig. 1.
6. Determine the maximum pressure drop across the valve and draw a horizontal line at this pressure in Fig. 1.
7. Draw a vertical line in Fig. 1 at the capacity (cf/h) previously determined. Use the corrected capacity for a gas with a specific gravity other than 0.64.
8. Use the valve size at the intersection of the horizontal and vertical lines. If the intersection is between valve sizes, use the next higher size to the right.

TO SIZE TWO IDENTICAL VALVES PIPED IN SERIES

1. Find the cf/h for the type of gas used.
2. Consider both valves as one unit. Determine the total maximum pressure drop across the unit.
3. Find the pressure drop across the first valve by assuming it to be 45 percent of the total pressure drop.
4. Find the valve size from Fig. 1.
5. The second valve will be the same size as the first valve.

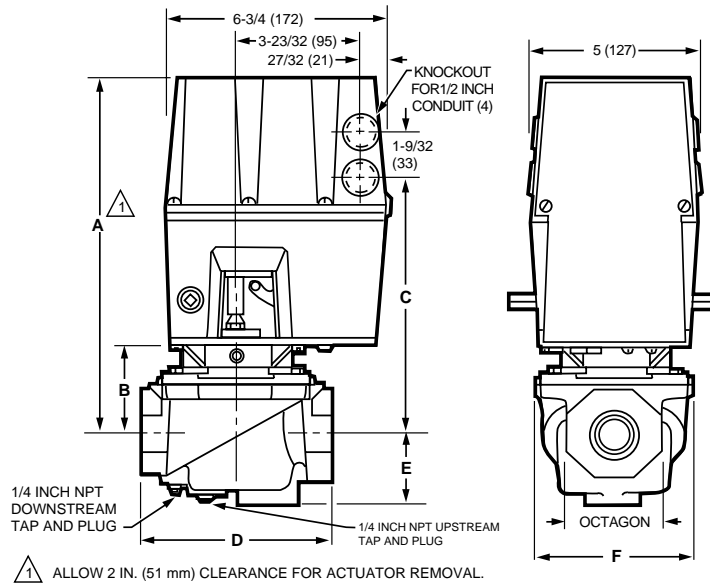

VALVE SIZE INCH	DIM A		DIM B		DIM C		DIM D		DIM E		DIM F		OCTAGON	
	IN.	MM	IN.	MM	IN.	MM	IN.	MM	IN.	MM	IN.	MM	IN.	MM
3/4	11-1/8	282.6	2-3/4	69.9	8-3/16	208.0	5-3/4	146.1	2-1/4	57.2	4-13/16	122.2	2-13/16	71.4
1	11-1/8	282.6	2-3/4	69.9	8-3/16	208.0	5-3/4	146.1	2-1/4	57.2	4-13/16	122.2	2-13/16	71.4
1-1/4	11-1/8	282.6	2-3/4	69.9	8-3/16	208.0	5-3/4	146.1	2-1/4	57.2	4-13/16	122.2	2-13/16	71.4
1-1/2	11-1/8	282.6	2-3/4	69.9	8-3/16	208.0	5-3/4	146.1	2-1/4	57.2	4-13/16	122.2	2-13/16	71.4
2	11-1/4	285.8	2-7/8	73.0	8-5/16	211.1	8-3/8	212.7	2-3/4	69.9	7-19/32	192.9	3-1/2	88.9
2-1/2	11-3/4	298.5	3-3/8	85.7	8-13/16	223.8	9-1/4	235.0	2-3/4	69.9	7-19/32	192.9	4-1/2	114.3
3	11-3/4	298.5	3-3/8	85.7	8-13/16	223.8	9-1/4	235.0	2-3/4	69.9	7-19/32	192.9	4-1/2	114.3

M9585

Fig. 2. Approximate dimensions of the 3/4 through 3 in. V5055 Valves, with valve actuator, in in. (mm).

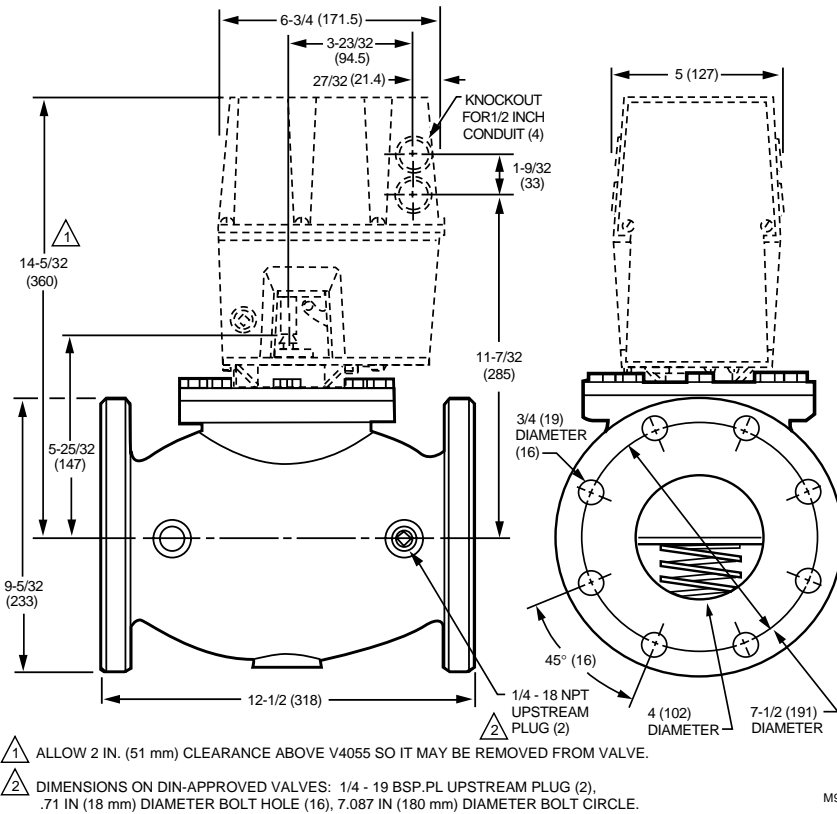

Fig. 3. Approximate dimensions of the 4 in. V5055 Valves, with valve actuator, in in. (mm).

INSTALLATION

IMPORTANT:

The V5055 Valve is designed to provide control of gaseous fuel (natural and LP gas) flow in applications in which there is minimal exposure to water. V5055 Valves used in maritime, beverage, food processing, outdoor and other installations in which occasional exposure to water is experienced may be subject to valve stem and spring corrosion. The presence of corrosion decreases the operating life of the valve. V5055 Valves used in such installations should be inspected at least annually and should have the valve bonnets replaced if corrosion is noted.

A V4055 Valve Actuator with a NEMA 4 rating is also recommended for such installations. The water-tight design of the NEMA 4 rated V4055 Actuator prevents water from entering the V4055 valve stem and spring chamber through the actuator. Under certain conditions, some water may be retained by the external upper portion of the valve body. The retained water is effectively excluded from the valve stem and spring chamber by a functional seal that is incorporated into the NEMA 4 rated actuator.

When Installing This Product...

1. Read these instructions carefully. Failure to follow them could damage the product or cause a hazardous condition.
2. Check the ratings given in the instructions and on the product to make sure the product is suitable for your application.
3. Installer must be a trained, experienced, flame safe-guard control technician.
4. After installation is complete, check out product operations as provided in these instructions.

WARNING

Electrical Shock Hazard and Explosion Hazard. Can cause serious injury, death or property damage.

1. Turn off gas supply before starting installation.
2. Disconnect power supply for valve actuator before beginning installation to prevent electrical shock and equipment damage.
3. Be sure the valve is installed so the arrow on the valve points in the direction of gas flow. (Gas pressure helps to close the valve.)

Location

Install the valve in the gas supply line downstream from the pressure regulator. The valve and actuator may be mounted in any position that allows sufficient clearance for installation and for repair or replacement.

1. The valve position indicators should be easily visible with the valve and actuator in the final position.
2. The final position of the valve and actuator must allow for damper linkage, if used.

IMPORTANT:

Allow room for turning the valve body (actuator not attached) onto the gas piping. Swing dimensions, measured from the center of the pipe are:

- 3/4 through 1-1/2 in. valves: 4 in. (101.6 mm).
- 2 through 3 in. valves: 5 in. (127.0 mm).
- 4 in. valves: 7 in. (177.8 mm).

Mounting (Figs. 4 through 6)

⚠ WARNING

Explosion Hazard.

Can cause serious injury, death or property damage.

If flow is not in the direction of the arrow on the valve body, the valve may not shut off.

1. Use new, properly reamed, pipe, free from chips.
2. Do not thread pipe too far (Fig. 4). Valve distortion or malfunction may result from excess pipe in the valve.

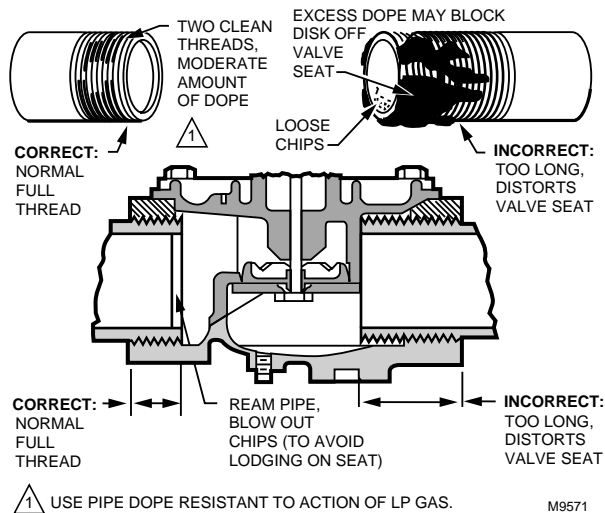

Fig. 4. Preparing the pipes.

3. Remove the protective caps from the ends of the valve. Do not attach the valve actuator until the valve body installation is complete.
4. Apply good quality pipe dope resistant to action of LP gas, putting a moderate amount on the male threads only. Use dope sparingly; if pipe dope lodges on the valve seat, it will prevent proper closure.
5. Install valve with the gas flow in the direction indicated by the arrow on the casting.
6. Apply a parallel jaw wrench only to the flat next to the pipe being inserted (Fig. 5). A wrench applied to the valve body itself, or to the end farthest from the pipe being inserted, may distort the casting, causing a malfunction. Do not use the valve for a lever.
7. Be sure the gas flow is in the same direction as the arrow on the bottom of the valve body.
8. Use two threaded companion flanges, two gaskets (included with valve), and 16 bolts (with washers and nuts) for mounting a 4 in.-V5055 Valve. Mount a threaded flange and gasket on each end of the valve as shown in Fig. 6. Then screw the pipes into the threaded flanges. Apply dope sparingly, and use wrenches and vises properly as shown in Fig. 4 and 5.
9. *Make sure the power supply is disconnected from the valve actuator.* Then mount the actuator on the valve body and complete the electrical and linkage connections following the instructions packed with the actuator.

OPERATION AND CHECKOUT

Operation

A V5055 Industrial Gas Valve is operated by a V4055, V4062, or V9055 Fluid Power Gas Valve Actuator. The valve opens when the actuator is energized, and closes when power is removed. When closed, the valve seals off against the rated close-off pressure with no power applied. For further information, refer to the Instructions for the actuator.

Checkout

⚠ WARNING

Explosion Hazard.

Can cause serious injury, death or property damage.

Do not allow fuel to accumulate in the combustion chamber. If fuel is allowed to enter the chamber for longer than a few seconds without igniting, an explosive mixture could result.

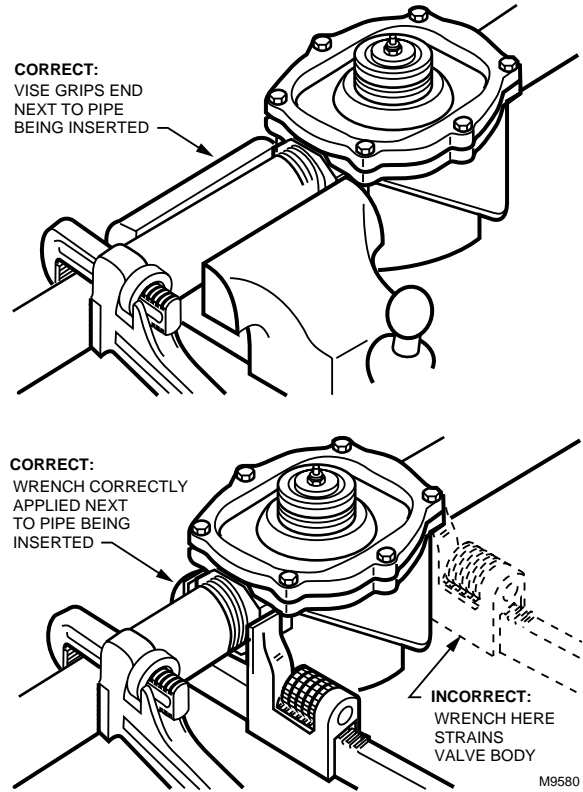

Fig. 5. Installing a 3/4 through 3 in. V5055 Valve.

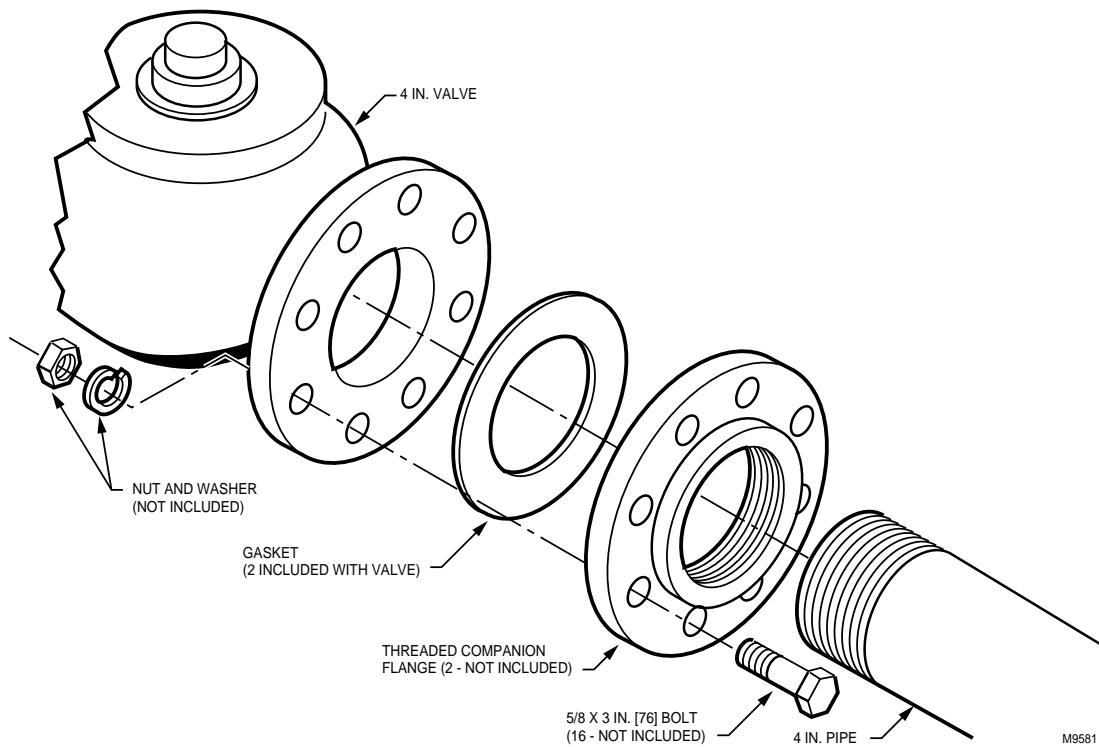

Fig. 6. Installing a 4 in. V5055 Valve.

CAUTION

Equipment Damage Hazard.
Operation without proper checkout can damage the equipment.

1. Do not put the system into service until you have satisfactorily completed the following Valve Leak Test, all applicable tests described in the Checkout section of the Instructions for the flame safeguard control, and any other tests required by the burner manufacturer.
2. All tests must be performed by a trained, experienced flame safeguard control technician.
3. Close all manual fuel shutoff valves as soon as trouble occurs.

After the installation is complete, cycle the valve several times with the manual fuel shutoff cock closed. Make sure the valve and actuator function properly. Also perform the Valve Leak Test that follows before putting the valve into service.

Valve Leak Test (Fig. 7)

This is a test for checking the closure tightness of a gas safety shutoff valve. It should be performed by qualified personnel during the initial startup of a burner system, or whenever the valve or valve bonnet is replaced (see Service Information section). It is recommended that this test also be included in the scheduled inspection and maintenance procedures. For a periodic inspection test, follow steps 1, 3, 4, 5, 8, 9, 10, 12, 13, 16, and 17.

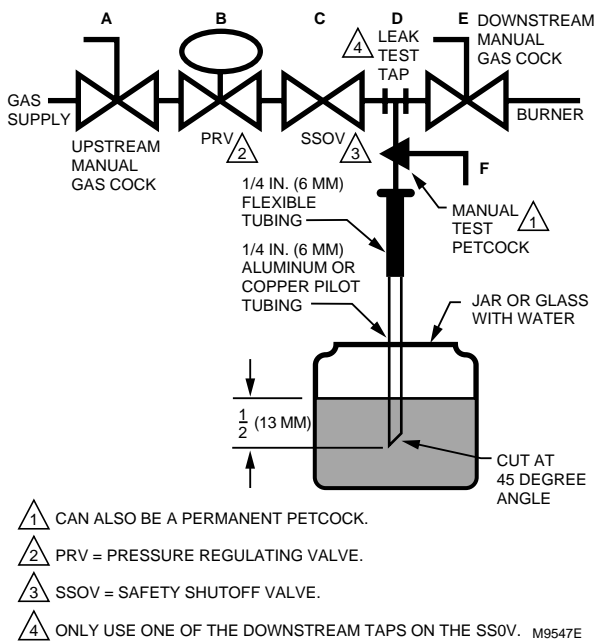

Fig. 7. Valve leak test.

1. De-energize the control system to assure that there is no power to the safety shutoff valve (C) shown in Fig. 7.
2. Close the upstream manual gas cock (A).
3. Make sure the manual test petcock (F) is closed in the leak test tap assembly (D).
4. Remove the leak test tap plug and connect the test apparatus to the Leak Tap (D).
5. Close the downstream manual gas cock (E).
6. Open the upstream manual gas cock (A).
7. Run the safety shutoff valve (C) to its fully open position (through the safety system); then immediately de-energize the system to close the valve.
8. Immerse a 1/4 in. tube vertically 1/2 in. (12.7 mm) into a jar of water.
9. Slowly open the test petcock (F).
10. When the rate of bubbles coming through the water stabilizes, count the number of bubbles appearing during a ten-second period. Each bubble appearing during a ten-second period represents a flow rate of approximately 0.001 cfh.

To meet U.S. requirements, leakage must not exceed the values listed in Table 4.

Table 5. Allowable Leakage for V5055 Valves.

V5055 Pipe Size (in.)	Allowable leakage (cc/hr) ^a	Number of bubbles per 10 sec.
3/4, 1, 1-1/4, 1-1/2	458	16
2, 2-1/2, 3	752	26
4	1003	35

^a Based on air at standard conditions, test pressures provided by ANSI Z21.21, Section 2.4.2 and a maximum of 235 cc/hr per inch of seal-off diameter. Seal-off diameter is not to be confused with pipe size.

NOTE: For international leak test requirements, contact the office of the appropriate approval agency.

After the test:

11. Close the upstream manual gas cock (A).
12. Close the test petcock (F), remove the test apparatus, and replace the leak test tap plug (D).
13. Open the upstream manual gas cock (A) and energize the safety shutoff valve (C).
14. Test with soap bubbles to assure that there is no leak at the test tap (D).
15. De-energize the safety shutoff valve (C).
16. Open the downstream manual gas cock (E).
17. Restore the system to normal operation. If two safety shutoff valves are utilized, each 550V valve is to be checked for tightness of closure.

SERVICE INFORMATION

⚠ WARNING

Explosion and Electrical Shock Hazard.
Can cause serious injury, death or property damage.

1. Before servicing, turn off the gas supply and disconnect all electrical power to the valve actuator.
2. Only qualified service technicians should attempt to service or repair flame safeguard controls and burner systems.
3. Do not disassemble the valve bonnet assembly; the valve seat is not replaceable.
4. Failure to properly position and seat the seals in the valve body may result in a hazardous gas leak.

Scheduled Inspection and Maintenance

Setup and follow a schedule for periodic inspection and maintenance, including the burner, all other controls, and the valve(s). It is recommended that the Valve Leak Test in the Checkout section be included in this schedule. Refer to the Instructions for the primary safety control for more information.

Valve Bonnet Replacement

The entire valve bonnet may be replaced without removing the valve body from the gas line. Do not disassemble the valve bonnet assembly; the valve seat is not replaceable.

For part numbers, refer to Replacement Parts in the Specifications section. Complete instructions for replacing the bonnet assembly are included with the replacement part.

Replacement of Seals (Fig. 8 or 9)

When removing the bonnet to inspect and clean the valve, install new seals (see Replacement Parts in Specifications section). Coat the new seals with the grease provided, and position them in the valve body as shown in Fig. 8 or 9.

Failure to properly position and seat the seals in the valve body may result in a hazardous gas leak.

After the new bonnet assembly is installed, or the bonnet is removed for any reason, check for gas leakage around the bonnet seal. Turn on the gas at the manual valve. Paint the seal area with a rich soap and water solution. Bubbles indicate a gas leak. If a leak is detected, check to see that the bonnet screws are tight. If necessary, turn off the gas again and remove the bonnet to be sure the seals are properly seated.

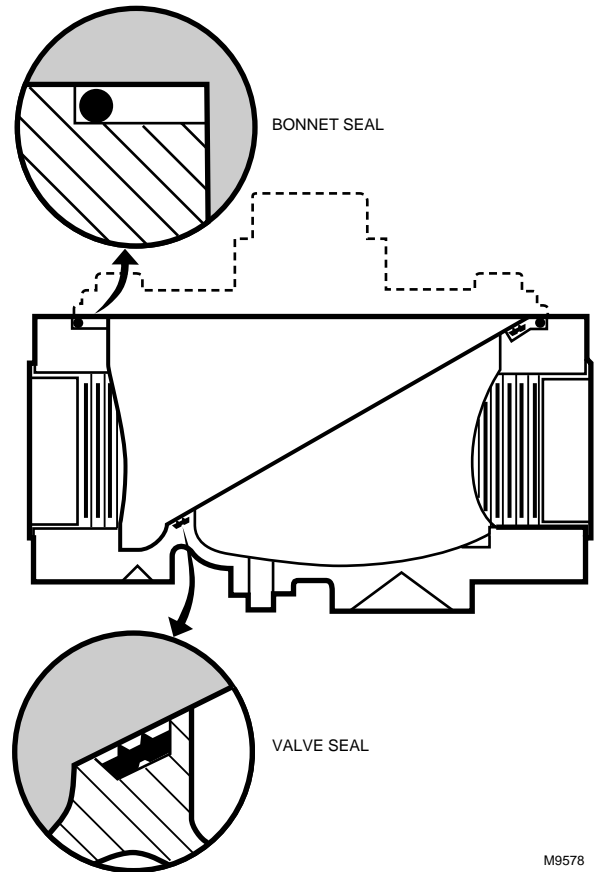

M9578

Fig. 8. Proper positions of valve and bonnet seals in 3/4 through 3 in. valves.

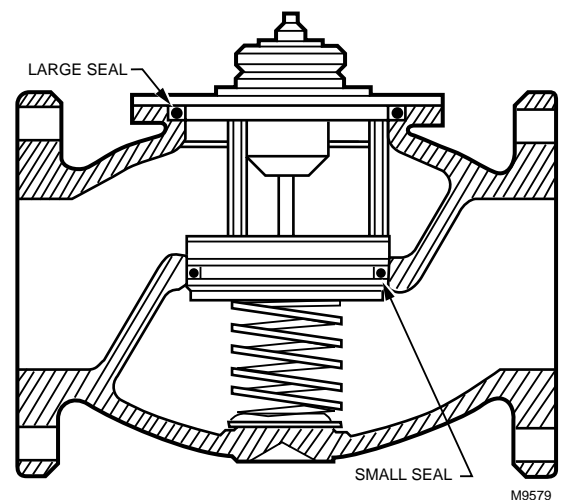

M9579

Fig. 9. Proper positions of valve and bonnet seals in 4 in. valve.

Honeywell

Home and Building Control Home and Building Control
Honeywell Honeywell Limited-Honeywell Limitée
1985 Douglas Drive North 35 Dynamic Drive
Golden Valley, MN 55422 Scarborough, Ontario
M1V 4Z9

