

V4055A,B,D,E On-Off Fluid Power Gas Valve Actuator

PRODUCT DATA



APPLICATION

The V4055 Gas Valve Actuator, in combination with a V5034, VE5000, V5055 or V5097 Gas Valve, controls the gas supply to commercial and industrial burners.

FEATURES

- The V4055 Actuator, when used with the V5034, VE5000, V5097 or V5055 Valve, is rated for final safety shutoff service.
- The V4055 Actuator can be used with the characterized guide model of the V5055 or V5097 Gas Valve to enhance lightoff smoothness.
- The standard model has an opening time of 26 seconds at 60 Hz or 32 seconds at 50 Hz. A fast-opening model is available with timings of 13 seconds at 60 Hz or 16 seconds at 50 Hz.
- Maximum closing time is one second, which meets code, standard and insurer requirements.
- Models available with damper shaft, with or without spring return; shaft extends out both sides and rides in Teflon-like Delrin bushings; used with standard 7616BR Damper Crank Arm.
- Red OPEN indicator attached to actuator stem shows when valve is even slightly open; yellow SHUT indicator on valve stem shows only when gas valve is fully closed.
- Models available with adjustable max flow limit switch.
- Ambient temperature rating is -40°F to +150°F (-40°C to +66°C) for 60 Hz models and -10°F to +158°F (-23°C to +70°C) for 50 Hz and 50/60 Hz models.
- Valve and actuator combinations can be mounted in any position, with the exception of the 220 to 240 Vac, 50/60 Hz models, which are mounted vertically.
- Models available with factory-installed single pole double throw (spdt) field-adjustable Auxiliary Switch. Field-addable Auxiliary Switch kits are also available.
- Standard enclosure meets NEMA 1 (IP30) requirements; models available with NEMA 4 weatherproof enclosure.
- V4055D and high pressure V4055E with Proof-of-Closure Switch and V5055/V5097C or E with valve seal overtravel interlock (double seal) to meet specific code, standard and insurer requirements.

Contents

Application	1
Features	1
Specifications	2
Ordering Information	2
Installation	4
Checkout and Service	7



SPECIFICATIONS

Models:

V4055A Actuator, with V5055, V5097 or VE5000 Gas Valves, provides on-off control of fuel. With proper adapter (see Accessories), it replaces the V4034 Actuator on a V5034 Gas Valve.

V4055B Actuator is a high pressure version of V4055A.

V4055D Actuator is identical to V4055A, except has a Proof-of-Closure Switch. Used with V5055C/V5097C (double seal) for valve seal overtravel interlock.

V4055E Actuator is identical to V4055B, except has a Proof-of-Closure Switch. Used with V5055E/V5097E (double seal) for valve seal overtravel interlock.

NEMA 4 weatherproof models available.

Nominal Opening Time:

See Table 1.

Table 1. Nominal Opening Time (seconds).

Model	50 Hz	60 Hz
Standard	32	26
Fast-opening	16	13

Maximum Closing Time:

One second when de-energized.

Ambient Operating Temperature Ratings:

60 Hz Models: -40°F to +150°F (-40°C to +66°C).

50 Hz, 50/60 Hz Models: -10°F to +158°F (-23°C to +70°C).

Mounting:

V4055 Actuator attaches directly to V5055 Valve with two sets of screws positioned 90 degrees apart. Combination is multipoise.

NOTE: 220 to 240 Vac, 50/60 Hz models are vertical mount only.

Pressure Ratings:

See Table 2.

ORDERING INFORMATION

When purchasing replacement and modernization products from your TRADELINE® wholesaler or distributor, refer to the TRADELINE® Catalog or price sheets for complete ordering number.

If you have additional questions, need further information, or would like to comment on our products or services, please write or phone:

1. Your local Home and Building Control Sales Office (check white pages of your phone directory).
2. Home and Building Control Customer Logistics
Honeywell Inc., 1885 Douglas Drive North
Minneapolis, Minnesota 55422-4386 (612) 951-1000

In Canada—Honeywell Limited/Honeywell Limitée, 155 Gordon Baker Road, North York, Ontario M2H 3N7.
International Sales and Service Offices in all principal cities of the world. Manufacturing in Australia, Canada, Finland, France, Germany, Japan, Mexico, Netherlands, Spain, Taiwan, United Kingdom, U.S.A.

Table 2. Pressure Ratings of Valve-Actuator Combinations.

Valve	Actuator							
	V4055A,D ^a				V4055B,E ^a			
	Differential ^b		Closeoff ^c		Differential ^b		Closeoff ^c	
	psi	mbar	psi	bar	psi	mbar	psi	bar
V5055/V5097A,C 3/4 to 3 in.	5	340	15	1	15	1000	15	1
V5055A,C 4 in.	3	200	15	1	5	340	15	1
V5055/V5097B 3/4 to 3 in.	5	340	15	1	15	1000	15	1
V5055B 4 in.	3	200	15	1	5	340	15	1
V5055/V5097D,E 3/4, 1-1/4, 1-1/2 in.	5	340	75	5	25	1700	75	5
V5055/V5097D,E 2, 2-1/2, 3 in.	5	340	45	3	15	1000	45	3

^a Use a V4055D or V4055E (with Proof-of-Closure Switch) with a V5055/V5097C or V5055/V5097E (with double seal) for valve seal overtravel interlock.

^b Maximum operating pressure differential.

^c Maximum closeoff pressure without seat leakage. This is the maximum valve pressure drop allowed while fully closed, and is independent of the valve body rating.

Electrical Ratings:

See Tables 3 and 4.

Table 3. V4055A,D Electrical Ratings.

Voltage and Frequency	Opening (Standard)				Opening (Fast)				Holding		
	Inrush	(W)	(A)	(VA)	Inrush	(W)	(A)	(VA)	(W)	(A)	(VA)
100/50-60 ^a	—	43.0	0.91	91	—	58.0	1.30	130	10.4	0.16	16
100/50-60 ^b	—	33.0	0.67	67	—	43.0	0.91	91	8.4	0.14	14
120/60	3.9	50.0	0.94	115	5.4	71.0	1.33	160	9.5	0.12	14
200/50-60 ^a	—	68.0	0.79	158	—	88.0	1.10	220	10.6	0.09	18
200/50-60 ^b	—	48.0	0.52	104	—	63.0	0.72	144	9.0	0.07	14
220/50	1.6	55.5	0.55	121	3.0	76.0	0.80	176	9.0	0.06	14
240/50	—	81.5	0.79	190	—	95.0	1.00	240	9.1	0.06	14
240/60	2.6	51.0	0.45	115	4.0	71.5	0.68	160	9.2	0.06	14
220-240/50-60 ^c	—	—	—	—	—	70.3	0.59	136	7.2	0.07	16
220-240/50-60 ^d	—	—	—	—	—	58.6	0.46	106	5.9	0.06	14

^a 50 Hz power supply.

^b 60 Hz power supply.

^c 230 Vac, 50 Hz power supply.

^d 230 Vac, 60 Hz power supply.

Table 4. V4055B,E Electrical Ratings.

Voltage and Frequency	Opening (Standard)				Opening (Fast)				Holding		
	Inrush	(W)	(A)	(VA)	Inrush	(W)	(A)	(VA)	(W)	(A)	(VA)
120/60	—	60	0.94	115	—	60.0	0.94	115	9.5	0.16	19
220-240/50-60 ^a	—	—	—	—	—	68.9	0.58	133	6.7	0.08	18
220-240/50-60 ^b	—	—	—	—	—	58.2	0.46	106	5.3	0.06	14

^a 230 Vac, 50 Hz power supply.

^b 230 Vac, 60 Hz power supply.

Auxiliary Switch and Proof-of-Closure Switch Ratings:
See Table 5.

Table 5. Auxiliary Switch and Proof-of-Closure Switch Ratings (1/2 hp [0.37kW]^a).

Load	120V	240V
Full Load	9.8A	4.9A
Locked Rotor	58.8A	29.4A

^aMaximum total connected power to both switches (if used) is 1800 VA.

Mounting Dimensions:
See Fig. 1.

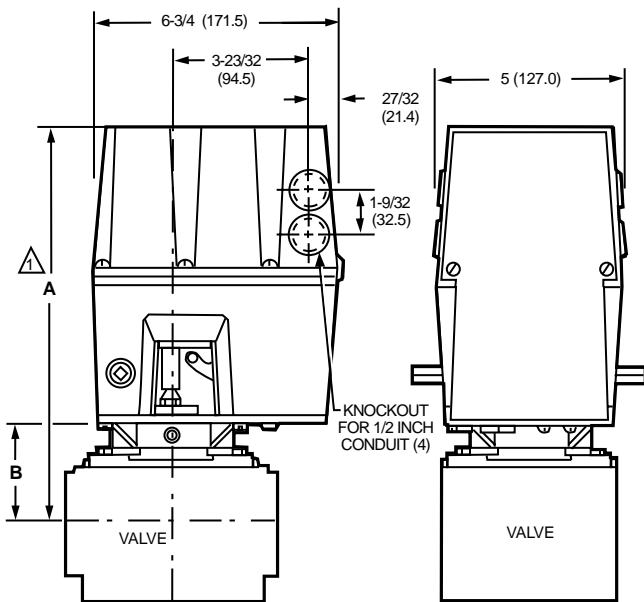

A ALLOW 4 IN. (101.6 MM) CLEARANCE FOR ACTUATOR REMOVAL.

VALVE SIZE INCH	V5055				V5097			
	DIM A		DIM B		DIM A		DIM B	
	IN.	MM	IN.	MM	IN.	MM	IN.	MM
3/4	11-1/8	282.6	2-3/4	69.9	11-1/8	283	2-3/4	70
1	11-1/8	282.6	2-3/4	69.9	11-1/8	283	2-3/4	70
1-1/4	11-1/8	282.6	2-3/4	69.9	11-1/8	283	2-3/4	70
1-1/2	11-1/8	282.6	2-3/4	69.9	11-1/8	283	2-3/4	70
2	11-1/4	285.8	2-7/8	73.0	11-3/4	298	3-3/8	86
2-1/2	11-3/4	298.5	3-3/8	85.7	11-3/4	298	3-3/8	86
3	11-3/4	298.5	3-3/8	85.7	11-3/4	298	3-3/8	86
4	14-1/8	358.8	5-13/16	147.6	—	—	—	—

M10981

Fig. 1. Approximate mounting dimensions of V4055 Actuators in in. (mm).

Damper Shaft:

Shaft is 3/8 in. (9.5 mm) square, for use with 7616BR Damper Crank Arm (ordered separately) and with or without damper shaft return spring.

Maximum Damper Shaft Rotation:

52 angular degrees.

Maximum Force:

2-11/16 in. (68.3 mm) radius for 7616BR Damper Crank Arm ordered separately (see Accessories section).

NOTE: Damper shaft drives damper crank arm in one direction only; optional return spring is available on damper shaft to turn damper crank arm in opposite direction. See Table 6.

Table 6. Actuator Torque (With and Without Return Spring).

V4055 Model	-40°F to 20°F [-40°C to -7°C]		20°F to 150°F [-7°C to 66°C]	
	(lb)	(N)	(lb)	(N)
With return spring	5	22.2	10	44.5
Without return spring	5	22.2	20	89.0

Approvals:

Underwriters Laboratories Inc. Listed: File No. MH1639, Guide No. YIOZ.

Factory Mutual: Approved.

International Approval Services (Joint Venture of the American Gas Association [AGA] and the Canadian Gas Association [CGA]): Certified 60 Hz models only.

Industrial Risk Insurers: Acceptable.

Some V4055 Actuators are approved as Class A valves in accordance with EN161:

When used with V5055 Valves: Pin: CE-0063AR1359.

When used with VE5000 Series Valves: Pin: CE-0063AP3075.

Accessories:

133533A Short Stem Adapter for mounting actuator on V5034 Valve.

133534A Long Stem Adapter for mounting actuator on V5034 Valve.

133568 Auxiliary Switch Bag Assembly (not for models with maximum flow limit switch).

133569 Valve-Closed Indication Switch Bag Assembly (not for use with V5034 Valve body).

7616BR Damper Crank Arm (damper arm and clip).

Q5055A1001 Adapter Assembly (adapts ITT General V710 Gas Valve to accept Honeywell gas valve actuators. Replaces ITT General AH2 Gas Valve actuators).

Available Models:

V4055 with NEMA 4 enclosure (weatherproof).

INSTALLATION

When Installing This Product...

1. Read these instructions carefully. Failure to follow them could damage the product or cause a hazardous condition.
2. Check the ratings given in the instructions and on the product to make sure the product is suitable for your application.
3. Installer must be a trained, experienced flame safeguard control technician.
4. After installation is complete, check out product operation as provided in these instructions.

WARNING

Electrical Shock Hazard.

Can cause serious injury or death.

Disconnect power supply before making wiring connections to prevent electrical shock and equipment damage.

IMPORTANT

1. All wiring must comply with all applicable electrical codes, ordinances, and regulations. All wiring must be NEC Class 1.
2. Voltage and frequency of the power supply connected to this control must agree with those marked on the device.
3. Loads connected to the Auxiliary Switch and/or Proof-of-Closure Switch, if used, must not exceed the ratings given in the Specifications section.

Install Valve

The actuator is mounted directly on the valve bonnet after the valve is installed in the gas supply line. Refer to the instructions packed with the gas valve for installation details.

When installing the gas valve, make sure:

1. Sufficient clearance is left to install and service the actuator.
2. Ambient temperatures at the valve location do not exceed actuator ratings. See Specifications section.
3. Position of the valve permits hookup to the damper if one is controlled.

Install Accessory Switches (If Needed)

An spdt switch can be installed to operate an auxiliary load up to 1/2 hp (0.37 kW). See Table 5. The switch can be adjusted to operate at any point in the valve stroke.

A Proof-of-Closure Switch can also be installed with a V5055/ V5097C or E Valve (with double seal) on any V4055 Actuator to provide a valve seal overtravel interlock. The spdt Proof-of-Closure Switch is installed to make or break a circuit when the valve is in the closed position. The switch is not adjustable.

NOTE: Mark the actuator or valve to indicate any changes made.

To install the switches:

1. Remove the actuator faceplate (two screws).
2. Remove the silver-colored barrier to expose the actuator stem.
3. Insert the Auxiliary Switch in the position indicated in Fig. 2. Fasten with two screws through the actuator base.
4. Insert the Proof-of-Closure Switch in the position shown in Fig. 2. The switch mounts against the side of the actuator housing. The mounting holes are spaced to assure mounting the switch in the correct position. Fasten with two screws through the actuator base. (The Proof-of-Closure Switch is not adjustable.)
5. If only one switch is used, install the narrow barrier included with the switch in the unused space.
6. Mount the actuator before making wiring connections and adjustments to the Auxiliary Switch.

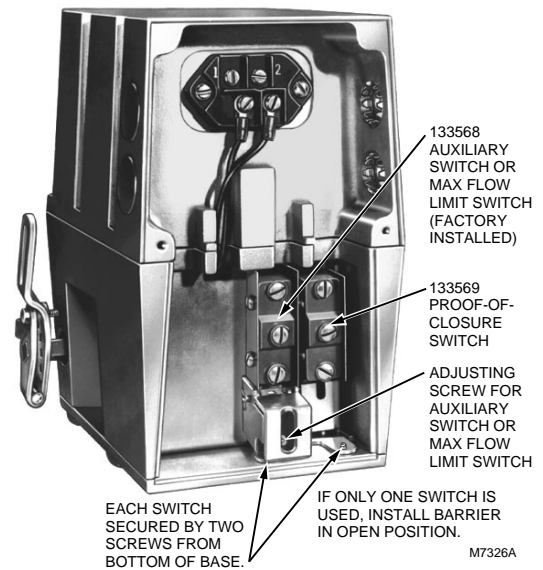

Fig. 2. V4055 Actuator with cover removed.

Mount Actuator on Valve

Check the final position of the valve body to be sure that the actuator is in the proper position when mounted on the valve. This is especially important when the actuator is used to drive a damper.

If two smaller sized valves are mounted very closely together, as in an Industrial Risk Insurers approved type of valve train, it may be necessary to mount the actuators off center to provide adequate clearance.

Slip the bottom collar of the actuator over the valve bonnet assembly. Rotate the actuator to the desired position and use a 5/32 in. Allen wrench to securely tighten the two setscrews to 50 to 60 lb-in. (5.7 to 6.8 N•m).

Connect the damper linkage, if used. Refer to the instructions packed with the damper arm.

Replace V4034 Actuator on V5034 Valve

IMPORTANT

When replacing a standard (26 sec) V4034 Actuator on a V5034 Valve, check the main burner flame-establishing period (MFEP) of the burner primary safety control. If the MFEP is 10 sec, you must use a fast-opening (13 sec) V4055 Actuator on the older V5034 Valve.

The initial action of the V4055 Actuator does not immediately open the V5034 Valve because of a difference in stroke length. The pilot may be shut off before the main burner flame is established. However, the fast-opening V4055 Actuator opens the V5034 Valve quickly enough to establish the main burner flame within the ten second flame-establishing period.

If it is desirable to maintain the slower opening characteristic of the standard V4034 Actuator, both the V4034 Actuator and V5034 Valve should be replaced with a standard V4055 Actuator on a V5055 Valve.

Select the correct adapter, depending on whether the V5034 Valve has a long or short stem (Fig. 3). Fasten the adapter to the V5034 Valve bonnet, and then mount the actuator on the adapter. Follow the instructions for mounting the actuator on the valve.

If the V4034 being replaced is equipped with a heater, there is a low limit control connected in series with the V4034 Actuator power supply to prevent actuator operation below 25°F (-4°C). There is also a constant source of line voltage power to the heater and thermostat.



Fig. 3. Use adapters to connect V4055 Actuator with V5034 Valve.

The V4055 is rated for ambient temperatures down to -40°F (-40°C) for 60 Hz models, or -10°F (-23°C) for 50 Hz and 50/60 Hz models, and does not require a heater. Remove all the wiring associated with the heater. Disconnect the power supply for the heater at its source and remove the wires. See Fig. 4.

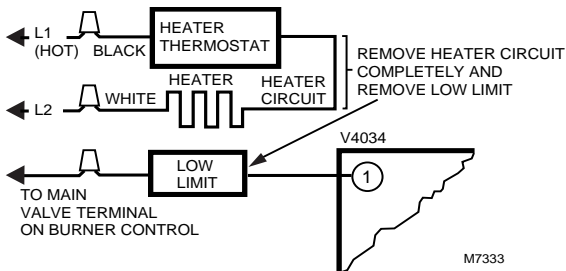

Fig. 4. Remove heater circuits, if installed, when replacing V4034 Actuator.

Mount and Adjust 7616BR Damper Crank Arm (If Used)

IMPORTANT

When a damper crank arm is used with a NEMA 4 actuator that is exposed to ice or sleet, a suitable shield must be installed to prevent ice or sleet buildup.

Follow installation and adjustment directions included with damper crank arm. Maximum pushrod travel is 2-5/16 in. (59 mm) through a stroke of 52 degrees. See Fig. 5.

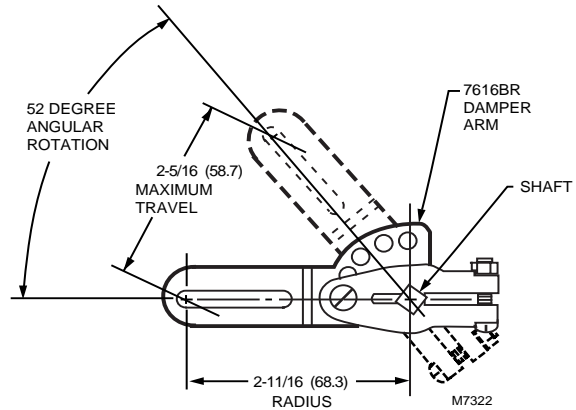

Fig. 5. 7616BR Damper Crank Arm can be attached to actuator shaft to drive a damper when valve is open.

Wiring

⚠ WARNING

Electrical Shock Hazard.

Can cause serious injury or death.

Disconnect power supply before making wiring connections to prevent electrical shock and equipment damage.

Wiring must comply with all applicable electrical codes, ordinances and regulations. Wiring to the actuator must be NEC Class 1.

Connect the power supply to terminals 1 and 2 on the V4055 terminal strip. Refer to Fig. 6 for Auxiliary Switch connections and Fig. 7 for Max Flow Limit Switch connections. For typical system hookups, refer to Fig. 8 and to instructions packed with the device used to control the valve.

When all wiring connections are complete, replace the actuator faceplate.

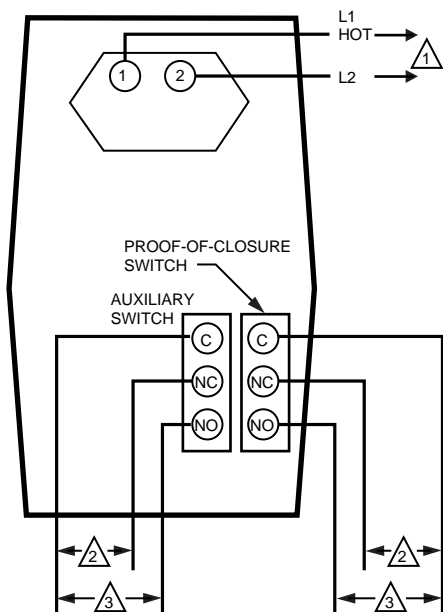

- ▲ 1 POWER SUPPLY. PROVIDE OVERLOAD PROTECTION AND DISCONNECT MEANS AS REQUIRED.
- ▲ 2 SWITCH BETWEEN THESE TWO LEADS IS CLOSED WHEN VALVE IS SHUT (DE-ENERGIZED).
- ▲ 3 SWITCH BETWEEN THESE TWO LEADS IS OPEN WHEN VALVE IS SHUT (DE-ENERGIZED).

M7334

Fig. 6. External connections to the V4055 Actuator.

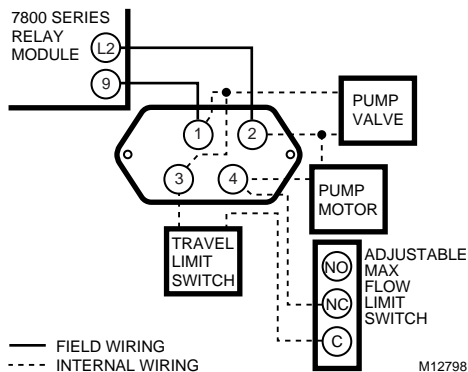

M12798

Fig. 7. Connecting the Max Flow Limit Switch to the actuator.

! CAUTION

Operation Hazard.
Improper wiring can cause improper and dangerous operation.

Label all wires prior to disconnection when servicing valves. Wiring errors can cause improper and dangerous operation.

NOTE: Pipe sealant is required on the conduit threads of actuators with NEMA 4 enclosures.

Adjust Auxiliary Switch (If Used)

The Auxiliary Switch is adjustable throughout the stroke of the actuator. With the switch installed in the actuator, turn the adjusting screw (see Fig. 2) clockwise ↻ to cause the switch to operate earlier in the stroke or counter-clockwise ↻ to cause the switch to operate later in the stroke.

NOTE: The Proof-of-Closure Switch is not adjustable.

Adjust Max Flow Limit Switch (If Used)

The Max Flow Limit Switch is adjustable throughout the stroke of the actuator. With the switch installed in the actuator, turn the adjusting screw clockwise ↻ to cause the switch to operate earlier in the stroke or counter-clockwise ↻ to cause the switch to operate later in the stroke.

CHECKOUT AND SERVICE

! CAUTION

Equipment Damage Hazard.
Unskilled technicians can cause equipment damage.

Only a trained, experienced, flame safeguard technician should check out and service this control.

Checkout

After the installation is complete, cycle the valve several times with the manual fuel shutoff cock closed before testing the system in actual operation.

Service

The actuator is not field repairable except for replacing the Auxiliary Switch, Max Flow Limit Switch or Proof-of-Closure Switch. See Installation section for procedure. Do not disassemble the valve actuator.

If the actuator fails to operate properly, replace it.

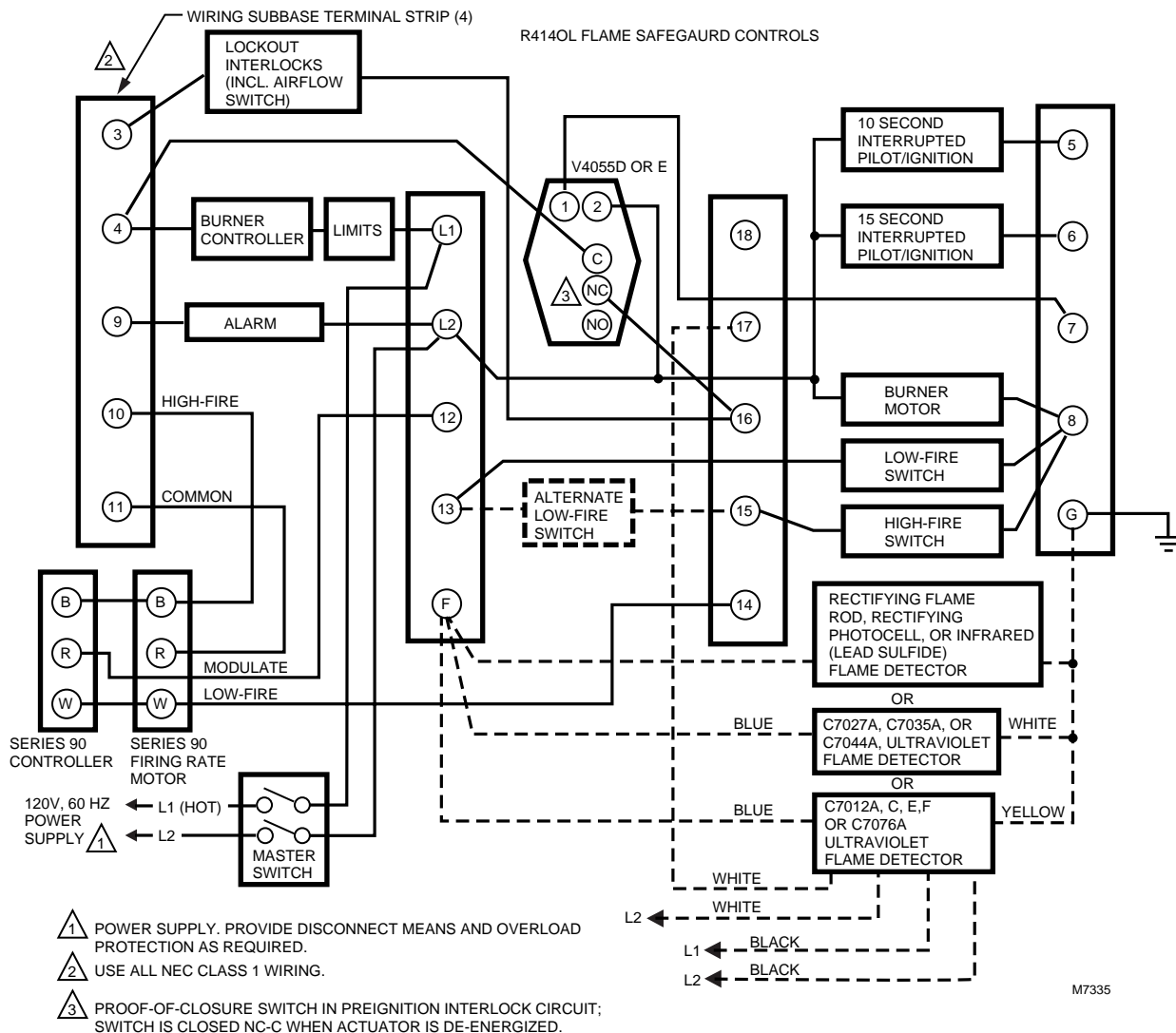

Fig. 8. Typical application of a V4055D/V5055C/V5097D or V4055E/V5055E/V5097E combination to meet Factory Mutual or Underwriters Laboratories Inc. approved requirements for Proof-of-Closure Switch (valve seal overtravel interlock).

Home and Building Control

Honeywell Inc.
Honeywell Plaza
P.O. Box 524
Minneapolis MN 55408-0524

Home and Building Control

Honeywell Limited-Honeywell Limitée
155 Gordon Baker Road
North York, Ontario
M2H 3N7

Honeywell Asia Pacific Inc.

Room 3213-3225
Sun Hung Kai Centre
No. 30 Harbour Road
Wanchai
Hong Kong

Honeywell Latin American Region

480 Sawgrass Corporate Parkway
Suite 200
Sunrise FL 33325

Honeywell Europe S.A.

3 Avenue du Bourget
1140 Brussels
Belgium

